

Study on
**Assessment of Water Foot
Prints of India's Long Term
Energy Scenarios**

The Study was sponsored with financial support of
Niti Aayog, Government of India

Conducted by
The Energy and Resources Institute (TERI), New Delhi



© The Energy and Resources Institute 2017

Disclaimer: The Energy and Resources Institute (TERI), New Delhi has received the grant under the Research Scheme of NITI Aayog 2015 to produce the document. However, NITI Aayog shall not be held responsible for findings or opinions expressed in the document prepared. This responsibility rests with The Energy and Resources Institute (TERI), New Delhi.

Suggested format for citation

TERI. 2017
Study of Assessment of Water Foot Prints of India's Long Term Energy Scenarios
New Delhi: The Energy and Resources Institute.
[Project Report No. 2015WM07]

For more information

Dr. Shresth Tayal
Fellow & Area Convenor
Water Resources Division

TERI
Darbari Seth Block
IHC Complex, Lodhi Road
New Delhi – 110 003
India

Tel. 2468 2100 or 2468 2111
E-mail stayal@teri.res.in
Fax 2468 2144 or 2468 2145
Web www.teriin.org
India +91 • Delhi (0)11

Contents

CONTENTS	III
TABLES	IV
FIGURES	V
1. INTRODUCTION, OBJECTIVES AND METHODOLOGY	8
1.1 An overview of India's energy sector vis-à-vis water availability in the country ..	8
1.2 Objectives	10
1.3 Approach and Methodology	10
1.4 Primary Survey Characteristics	14
2 REGIONAL ASSESSMENT OF WATER AVAILABILITY AND ITS REQUIREMENT	18
2.1 Western Region	18
2.2 Southern Region.....	21
2.3 Central Region.....	26
2.4 Eastern Region.....	30
2.5 Northern Region	34
2.6 North Eastern Region.....	39
3 SPATIAL AND TEMPORAL VARIATION IN WATER AVAILABILITY AND STRESS	42
3.1 Seasonal variation in water availability and stress	42
3.2 Inter-regional assessment of variability in water availability and demand	46
4 ASSESSMENT OF WATER STRESS FOR FUTURE SCENARIOS	55
4.1 Projections under Business As Usual scenarios.....	55
4.2 Projections under Specific Government Schemes	63
4.3 Projections under Climate Change scenarios.....	67
5 EFFICIENT WATER USE IN ENERGY DEMAND & SUPPLY SECTORS	71
5.1 Energy demand sectors	71
5.2 Energy Supply Sectors.....	77
5.3 Efficient water use in Fossil based power generation.....	77
5.4 Efficient water use in Nuclear power stations	79
5.5 Efficient water use in renewable based bio-energy.....	79
5.6 Efficient water use in oil & gas extraction	80
6 RECOMMENDATION ON CHANGE IN POLICY, REGULATORY FRAMEWORK OR INSTITUTIONAL ARRANGEMENT IN INDIA	83
6.1 Establishing Institutional synergies	83
6.2 Specific Policy Recommendations for Thermal Power Plants	85
ANNEXURE	86
Water-Energy Nexus Footprinting of Thermal Electricity Production.....	86

Tables

TABLE 2.1: SECTORAL WATER DEMAND IN WESTERN REGION	21
TABLE 2.2: SECTORAL WATER DEMAND IN SOUTHERN REGION.....	25
TABLE 2.3: SECTORAL WATER DEMAND IN CENTRAL REGION.....	29
TABLE 2.4: SECTORAL WATER DEMAND IN EASTERN REGION	33
TABLE 2.5: SECTORAL WATER DEMAND IN NORTHERN REGION.....	38
TABLE 2.6: SECTORAL WATER DEMAND IN NORTH-EASTERN REGION	41
TABLE 3.1: MONTHLY DISTRIBUTION OF RAINFALL IN DIFFERENT REGIONS.....	43
48	
TABLE 3.2: WATER RESOURCES OF INDIA.....	48
TABLE 3.3: BASELINE WATER STRESS CATEGORIES AND STRESS PERCENTAGE.....	53
TABLE 3.4: REGIONAL WATER STRESS CATEGORIZATION	53
TABLE 4.1: LITRE PER CAPITA PER DAY (LPCD) NORMS FOR RURAL AND URBAN AREAS.	58
TABLE 4.2: BASE LEVEL CAGR GROWTH OF INDUSTRIES (SOURCE: IESS-2047)	59
TABLE 4.3: CAGR FOR COAL BASED INSTALLED CAPACITY	60
TABLE 4.4: REGIONAL WATER STRESS UNDER BAU SCENARIO	62
TABLE 4.5: REGIONAL WATER STRESS UNDER CLIMATE CHANGE SCENARIO.....	70
TABLE 5.1 VARIOUS WATER CONSERVATION MEASURES (IN LAST 4 YEARS) IN THE PLANT	76

Figures

FIGURE 1.1 SHARE OF VARIOUS ELECTRICITY SOURCES	8
FIGURE 1.2 OVERVIEW OF SCOPE OF WORK	11
FIGURE 1.3: OVERALL APPROACH TO IDENTIFY WATER STRESS SCENARIOS IN STATES VIS A VIS ENERGY PRODUCTION.....	13
FIGURE 1.4 SURVEY LOCATIONS FOR ENERGY DEMAND SECTORS	15
FIGURE 1.5 SURVEY MAP OF ENERGY SUPPLY (THERMAL POWER PLANTS) LOCATIONS	17
FIGURE 2.1: LOCATION MAP OF WESTERN REGION	18
FIGURE 2.2: RAINFALL DISTRIBUTION IN WESTERN REGION.....	18
FIGURE 2.3A: NET SURFACE WATER AVAILABILITY IN STATES OF THE WESTERN REGION..	19
FIGURE 2.3B: NET GROUNDWATER AVAILABILITY IN STATES OF THE WESTERN REGION...	19
FIGURE 2.4A: URBAN WATER DEMAND IN THE WESTERN REGION.....	20
FIGURE 2.4B: RURAL WATER DEMAND IN THE WESTERN REGION	20
FIGURE 2.5: LOCATION MAP OF SOUTHERN REGION	21
FIGURE 2.6: STATE-WISE RAINFALL DISTRIBUTION IN SOUTHERN REGION.....	22
FIGURE 2.7A: STATE-WISE DISTRIBUTION OF SURFACE WATER AVAILABILITY IN SOUTHERN REGION	23
FIGURE 2.7B: STATE-WISE DISTRIBUTION OF GROUND WATER AVAILABILITY IN SOUTHERN REGION	23
FIGURE 2.8A: STATE-WISE PER UNIT LAND WATER AVAILABILITY IN SOUTHERN REGION .	23
FIGURE 2.8B: STATE-WISE PER CAPITA WATER AVAILABILITY IN SOUTHERN REGION	23
FIGURE 2.9: STATE-WISE POPULATION DISTRIBUTION IN SOUTHERN REGION	24
FIGURE 2.10A: URBAN WATER DEMAND IN THE SOUTHERN REGION.....	24
FIGURE 2.10B: RURAL WATER DEMAND IN THE SOUTHERN REGION	24
FIGURE 2.11: LOCATION MAP OF CENTRAL REGION.....	26
FIGURE 2.12: STATE-WISE RAINFALL DISTRIBUTION IN CENTRAL REGION.....	26
FIGURE 2.13A: STATE-WISE DISTRIBUTION OF SURFACE WATER AVAILABILITY IN CENTRAL REGION	27
FIGURE 2.13B: STATE-WISE DISTRIBUTION OF GROUND WATER AVAILABILITY IN CENTRAL REGION	27
FIGURE 2.14A: STATE-WISE PER UNIT LAND WATER AVAILABILITY IN CENTRAL REGION ..	27
FIGURE 2.14B: STATE-WISE PER CAPITA WATER AVAILABILITY IN CENTRAL REGION	27
FIGURE 2.15: NET CROP AREA AND NET IRRIGATED AREA IN CENTRAL REGION	28
FIGURE 2.16: STATE-WISE POPULATION DISTRIBUTION IN CENTRAL REGION	29
FIGURE 2.17: LOCATION MAP OF EASTERN REGION	30
FIGURE 2.18: STATE-WISE RAINFALL DISTRIBUTION IN EASTERN REGION	30
FIGURE 2.19A: STATE-WISE DISTRIBUTION OF SURFACE WATER AVAILABILITY IN EASTERN REGION	31
FIGURE 2.19B: STATE-WISE DISTRIBUTION OF GROUND WATER AVAILABILITY IN EASTERN REGION	31
FIGURE 2.20: NET CROP AREA AND NET IRRIGATED AREA IN EASTERN REGION.....	31
FIGURE 2.21: STATE-WISE POPULATION DISTRIBUTION IN EASTERN REGION.....	32
FIGURE 2.22A: URBAN WATER DEMAND IN THE EASTERN REGION	32
FIGURE 2.22B: RURAL WATER DEMAND IN THE EASTERN REGION.....	32
FIGURE 2.23: LOCATION MAP OF NORTHERN REGION.....	34
FIGURE 2.24: STATEWISE RAINFALL DISTRIBUTION IN NORTHERN REGION	34
FIGURE 2.25A: STATE-WISE DISTRIBUTION OF SURFACE WATER AVAILABILITY IN NORTHERN REGION	35
FIGURE 2.25B: STATE-WISE DISTRIBUTION OF GROUND WATER AVAILABILITY IN NORTHERN REGION	35
FIGURE 2.25C: STATE-WISE PER UNIT LAND WATER AVAILABILITY IN NORTHERN REGION	35
FIGURE 2.25D: STATE-WISE PER CAPITA WATER AVAILABILITY IN NORTHERN REGION	35
FIGURE 2.26: NET CROP AREA AND NET IRRIGATED AREA IN NORTHERN REGION.....	36
FIGURE 2.27: STATE-WISE POPULATION DISTRIBUTION IN NORTHERN REGION	37

FIGURE 2.28A: URBAN WATER DEMAND IN THE NORTHERN REGION	37
FIGURE 2.28B: RURAL WATER DEMAND IN THE NORTHERN REGION	37
FIGURE 2.29: LOCATION MAP OF ASSAM, NORTH-EASTERN REGION	39
FIGURE 2.30: RAINFALL DISTRIBUTION IN ASSAM, NORTH-EASTERN REGION	39
FIGURE 2.31A: URBAN WATER DEMAND IN THE NORTH EASTERN REGION	40
FIGURE 2.31B: RURAL WATER DEMAND IN THE NORTH EASTERN REGION	40
FIGURE 3.1: LEAN PERIOD SURFACE WATER DISTRIBUTION	44
FIGURE 3.2: LEAN PERIOD TOTAL WATER DISTRIBUTION	44
FIGURE 3.3: GROUPING OF DIFFERENT STATES INTO REGIONS	46
FIGURE 3.4: RAINFALL DISTRIBUTION IN INDIA	47
FIGURE 3.5: VARIATION IN AVERAGE ANNUAL RAINFALL IN DIFFERENT REGIONS	48
FIGURE 3.6 A: REGION-WISE DISTRIBUTION OF POTENTIALLY UTILIZABLE SURFACE WATER RESOURCES	49
FIGURE 3.6 B: REGION-WISE DISTRIBUTION OF POTENTIALLY UTILIZABLE GROUND WATER RESOURCES	49
FIGURE 3.7: NET CROP AREA AND NET IRRIGATED AREA ACROSS DIFFERENT REGIONS.....	50
FIGURE 3.8: IRRIGATION WATER REQUIREMENT ACROSS DIFFERENT REGIONS	50
FIGURE 3.9A: REGION WISE URBAN POPULATION OF INDIA.....	51
FIGURE 3.9B: REGION WISE RURAL POPULATION OF INDIA.....	51
FIGURE 3.10: REGION-WISE DOMESTIC WATER REQUIREMENT IN THE COUNTRY	51
FIGURE 3.11A: WATER FOR THERMAL ELECTRICITY PRODUCTION	52
FIGURE 3.11B: WATER FOR ENERGY PRODUCTION	52
FIGURE 4.1 : COMPOUNDED ANNUAL GROWTH RATE IN NET IRRIGATED AREA FOR DIFFERENT STATES	56
FIGURE 4.2 : PERCENTAGE DECADEAL CHANGE IN IRRIGATION WATER REQUIREMENT.....	56
FIGURE 4.3 : PERCENTAGE CHANGE IN RURAL AND URBAN POPULATION IN INDIA BY 2050	57
FIGURE 4.4 : PERCENTAGE DECADEAL CHANGE IN RESIDENTIAL WATER REQUIREMENT	58
FIGURE 4.5 : DECADEAL CHANGE IN RESIDENTIAL WATER REQUIREMENT FOR DIFFERENT REGIONS	59
FIGURE 4.6: DECADEAL CHANGE IN INDUSTRIAL WATER REQUIREMENT FOR DIFFERENT REGIONS	60
FIGURE 4.7 : DECADEAL CHANGE IN WATER REQUIREMENT FOR ENERGY PRODUCTION IN DIFFERENT REGIONS.....	61
FIGURE 4.8 : DECADEAL CHANGE IN TOTAL WATER REQUIREMENT FOR ENERGY PRODUCTION IN THE COUNTRY.....	61
FIGURE 4.9 : DECADEAL CHANGE IN MINIMUM WATER REQUIREMENT IN DIFFERENT REGIONS	62
FIGURE 4.10: COUNTRY WIDE REDUCTION IN IRRIGATION WATER CONSUMPTION BY 2021 AND 2031, UNDER PMKSY SCENARIOS.....	64
FIGURE 4.11A: REGION-WISE REDUCTION IN IRRIGATION WATER CONSUMPTION BY 2021, UNDER PMKSY SCENARIOS.....	64
FIGURE 4.11B: REGION-WISE REDUCTION IN IRRIGATION WATER CONSUMPTION BY 2031, UNDER PMKSY SCENARIOS.....	65
FIGURE 4.12 : CHANGES IN RAINFALL PATTERN FOR STATES.....	68
FIGURE 4.13 : PERCENTAGE CHANGE IN SURFACE WATER AVAILABILITY UNDER CLIMATE CHANGE SCENARIO	69

1. Introduction, Objectives and Methodology

An overview of India's energy sector vis-à-vis water availability in the country

Adequate availability of energy makes a fundamental pre-requisite for the economic development of a country. Moreover, for India's strive to transform from a developing economy to a developed country, it becomes extremely relevant to ensure energy security for the country. In the world, India ranks 5th in terms of electricity generation and is 6th largest energy consumer in the world. In the past 30 years, due to economic development, the energy demand has grown at an average rate of 3.6% per year. It is expected that the total demand for electricity in India is expected to cross 950,000 MW by 2030. India is a growing economy and its demand for energy is increasing with time to achieve the development needs. As per the World Energy Outlook 2015, India has registered almost 10% of increase in global energy demand since 2000. However the per capita demand is not this impressive and has shown modest rise of 46% since 2000. Building sectors which includes both residential and services had the dominating share in the past but demand in industry has grown more rapidly since 2000, overtaking buildings as the main energy user in 2013.

Currently, India has total installed capacity of 310,005 MW as on 31 December 2016. The share of various electricity sources is presented below. Thermal is the largest source of energy production in India followed by renewables. Thermal power plants are water intensive entities.

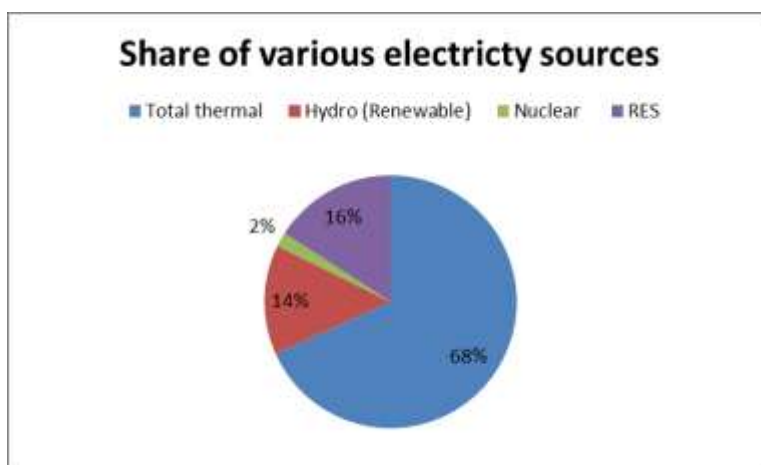

Figure 1.1 Share of various electricity sources

However, energy security is inextricably linked to the availability of water. Both energy demand and supply sectors need water for various processes.

Energy supply sector includes different power producing sectors like coal based power plants, nuclear power plants; renewables based power production, etc. For production of energy, water is an indispensable input at all the stages including the extraction of fuel, refining and washing of fuel as well as thermal production of electricity. While, energy demand sectors are agriculture, domestic or buildings and industrial sector. All these sectors need energy for various processes and these energy demand sectors also need water.

With 18% of world's population and only 4% of the world's water resources, India is already a water stressed nation and per capita water availability is declining rapidly. Inter-sectoral

competition between various water demand sectors (which includes both energy demand and supply sectors) is becoming fiercer. In fact most of the power plants in India are located in water stressed region of the country, thus adding more pressure to the finite water resource. It has also been reported that some of the power plants in the country were forced shut down in the past because of unavailability of the reliable supply of fresh water to sustain plant's operations. Thermal Power Plants are reported to be accounting for 87.8% of total industrial water consumption in the country. Average consumptive water requirement for coal based plants with cooling tower in India is about 5-7 m³/h per MW. As such, thermal power production in the country is consuming atleast 16.8 million m³ of water per day at 80% load factor, which is equivalent to per capita water requirement of about 20% population of the country.

Even in energy demand sectors, agriculture which is the most dominant water user faces an issue on account of spatial & temporal variability of availability of water for irrigation. There has been number of studies available highlighting the nexus between water and energy and how the two are intricately linked.

However, the demand for energy is ought to increase in all the sectors and to meet the demand intensive supply is needed. For both energy demand and supply sectors, water is important and the demand for water will rise in both energy production and energy demand.

With the depleting water resources in the country, achieving energy security is going to be a big challenge if water is not given due consideration while planning energy policy and programs. Therefore, it becomes essentially important to understand the water footprint of India's long term energy scenarios, and ensure efficient management of water availability to balance its influence on energy production in the country. Spatial and temporal variations in water availability across different regions of the country, and growing concerns related to variability in rainfall pattern, enhance the significance of developing a sound knowledge base to make informed policy and decision making related to energy production in the country.

One of the major issues in the context of water-energy nexus is that the both sectors are managed independent of each other. Achieving energy and water security are two different targets but they cannot be achieved unless their complimentary is well understood. Both energy and water policies and programs are developed in-silos, often ignoring the common grounds. It is important to take these issues together and explore common solutions.

Niti Aayog has developed a tool known as IESS 2047 which is essentially an energy scenario building tool. This tool provides information about likely energy demand and supply scenarios. This tool helps various stakeholders in making informed decisions regarding policies and programs. But as water is inextricably linked to energy, therefore it becomes imperative to understand the implication of different energy demand supply scenarios on water resources.

Objectives

- To assess the water footprint of India's long term energy scenarios in energy demand and supply sectors as follows:
 - Demand sectors: i) Agriculture, ii) Industries, iii) Domestic
 - Supply sectors: i) Fossil based power generation, ii) coal washeries, iii) Nuclear power stations, iv) Renewable based bio-energy, v) Oil & gas extraction
- To investigate the potential for improving water efficiency in the sector and suggest methods of efficient utilization of water in above industries
- To evaluate the regional water requirement

Approach and Methodology

Regional analysis has been undertaken for various energy demand and supply sectors across India. All the states have been grouped into geographical regions to undertake regional level analysis. Secondary and Primary data has been collected for various energy demand and supply sectors to evaluate water requirement in each of the listed sectors. It also investigates the regional water availability in the context of rainfall, potentially utilizable surface water and ground-water resources. Water demand at the regional level was estimated for all the sectors and similarly water availability for the region was assessed to understand the water stress because of water availability and water demand from various sectors.

Further, the study investigates projected water demand for various sectors to understand the course of water demand *viz.-a-viz.* energy demand /supply in the country.

Some of the international best practices on efficient water use in various sectors have been reviewed and presented to explore the opportunities for saving water in India in various sectors. Additionally, regulatory and institutional level recommendations have also been provided with respect to water utilisation and better management of water resources across the sectors.

The scope of work and the activities carried out is presented in the figure below.

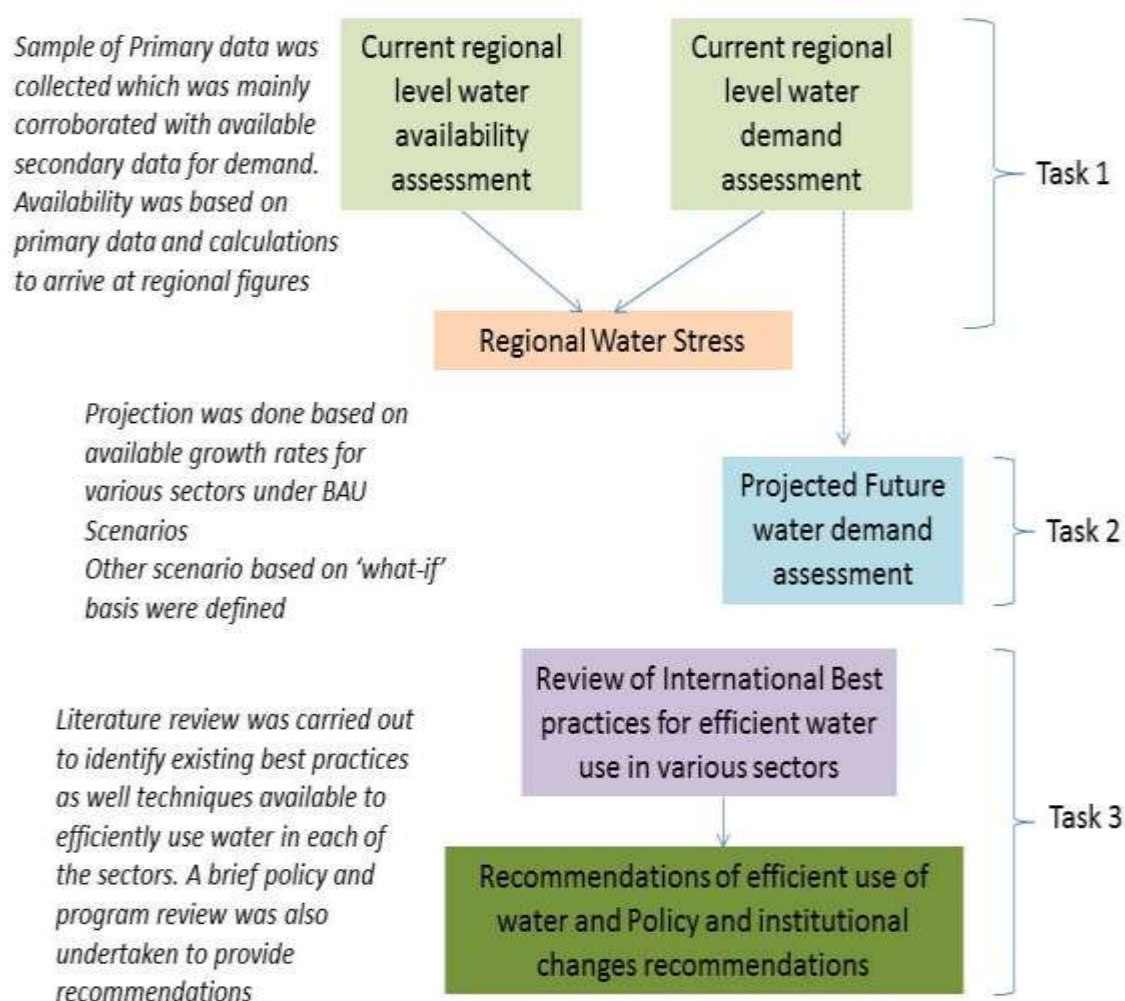

Figure 1.2 Overview of Scope of Work

Integrating different Datasets on GIS platform

A key challenge behind studying water stress in different states was integrating different datasets which are available in different spatial units. Whereas information related to river water flow and water availability is available at the level of river basins, information about other parameters like demographic characteristics, agriculture etc. are available at the administrative scale i.e., district or state level. Moreover, data on rainfall distribution is available at the level of meteorological sub-divisions identified by Indian Meteorological Department. Administrative boundaries, hydrological boundaries and meteorological sub-division boundaries do not follow each other and are at different spatial scale. Hence, it was important to bring all the relevant information related to present study at the same scale. The approach for this assessment involved two main components – delineation of different type of boundaries, digitization and GIS layer preparations for different water regulating factors at the state level.

Geographical Information System (GIS) was used to delineate river basins, meteorological sub-divisions, digitize water demand parameters and distribute them across the river basins. Figure (1.3) presents the schematic diagram of the approach adopted for the study.

Watershed Delineation using geospatial tools

Watersheds, also known as basins or catchments, are physically delineated by the area upstream from a specified outlet point. Watersheds can be delineated manually using paper maps, or digitally in a GIS environment. For present study, watershed delineation was done by using ArcGIS 10 and ERDAS imagine 9.2 software. Digital Elevation Model (DEM) were used to delineate river basins and generate drainage network within the basin.

1.1.1.1 Mapping water availability regulators

To map the water regulating parameters, below mentioned datasets were brought into the GIS platform:

Political boundary on the scale of National, State and district level of the country

River basin maps

Rainfall data from meteorological sub-divisions

Digital Elevation Model

Basin Boundary Delineation – To delineated river basin boundary, we have used Digital Elevation Model for calculating stream network and flow accumulation of the basing using Hydrology tool of the Geographical information system.

State wise Area Distribution – To estimate the state wise area sharing in the basin we used clip management tool of the Geographical Information System which helps to extract the state boundary which lies under the basin boundary.

District wise area distribution - To estimate the district wise area sharing in the basin we used clip management tool of the Geographical Information System which helps to extract the district boundary which lies under the basin boundary.

Rainfall Distribution in the basin – Rainfall is the key source of the surface water flow in the basin which needs to assess for estimating total water availability in the basin. In this context, we distributed district wise rainfall in the basin using symbology technique which defines the rainfall ranges varying from low to high.

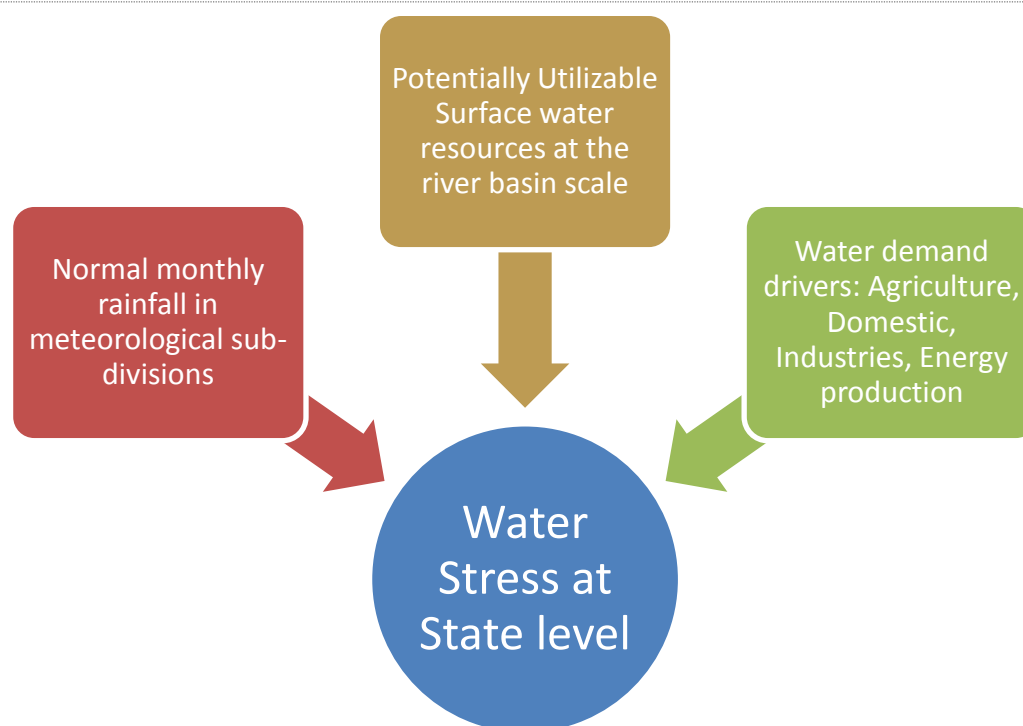

Figure 1.3: Overall approach to identify water stress scenarios in states *vis a vis* energy production

Water Demand modelling

Water demand assessment for different water users is important to understand the stress between the sectors for limited water resource. We assessed sectoral water demand and water balance of the watershed to understand the water stress scenarios based on the available water resource and imposed demand by major sectors. For the purpose, PODIUM Sim model was used. PODIUM Sim - the policy dialogue model was developed by the International Water Management Institute (IWMI) in 1999 as part of the Vision 2025 exercise. The four major components of PODIUM Sim are Consumption, Production, Water Demand and Water Supply. The model maps the complex relationships between numerous factors (drivers in the model) that affect water demand and supply. Projections for future years are determined in relation to base year data by the expected changes in the drivers over this period. PODIUM Sim estimates water demand for the following three major sectors; agriculture, industries, domestic. For all the sectors, model has fixed list of common drivers which regulate the ultimate water demand.

1.1.1.2 Agriculture water demand

Agriculture sector is the most intensive water user due to requirement of water for irrigation. Different crops have different water requirement during their development stages. The term water requirements of a crop means the total quantity of all water and the way in which a crop requires water, from the time it is sown to the time it is harvested. The water requirement of crop varies with the crop as well as with the

place. The same crop may have different water requirements at different places; depending upon the climate, type of soil, method of cultivation and useful rainfall. The requirement of water for the growth of the plant depends both on the transpiration from the plant and evaporation from the surface.

Thus, key drivers for irrigation water requirement are area under irrigation, type of crop and growth period of crops. PODIUM Sim model estimates the irrigation water requirement based on these important drivers. Secondary data sourced from authentic government sources was used for these drivers where available.

1.1.1.3 Domestic water demand

Domestic water demand majorly comprises of requirement of water for drinking, cooking, bathing, washing, flushing of toilet, gardening, etc. Also, domestic water demand includes water demand for both – human beings and livestock. Domestic water demand is regulated primarily by the total number of people (or livestock) in an area and their daily water requirement. As water consumption in rural and urban areas is different, percentage of urbanisation in an area also has a significant impact on its total water demand. Data on all these parameters was provided as input to the model to calculate state level domestic water requirement.

1.1.1.4 Industrial Water Demand

To find industrial water requirement for each state, we selected 5 most water intensive industries and used the information related to their installed capacity, average production in 2010 and specific water consumption for per unit production for these industries. This data was supplied to PODIUM Sim to model industrial water requirement at the state level.

Primary Survey Characteristics

For collection of primary data from various demand sectors, survey was done in selected states of India. The brief about survey characteristics of each of the surveyed state is presented in this section. Surveys were done through structured questionnaire specific for each sector. The information collected from various sector was used to corroborate the available and authentic secondary information to further undertake analysis and assessment.

From the northern region, Uttar Pradesh, Haryana and Himachal Pradesh were the surveyed states. In Uttar Pradesh, two districts were surveyed, Bareilly from Western Uttar Pradesh and Varanasi from Eastern Uttar Pradesh. In Bareilly district, two villages, Ghura-Raghavpura and Murapura were surveyed for agriculture sub sector. The main crop grown in the village is wheat (Rabi), while paddy, maize, etc. are Kharif crops. The average land holding size of the surveyed farmers are in the range of 0.1-7.4 hectares. All the farmers are dependent on irrigation source for farming and as per Comprehensive District Agricultural Plan (C-DAP), Bareilly has around 85-90% area under irrigation with cropping intensity of 165%. The common irrigation source is ground water. DG sets are used to abstract the water from the ground and on an average wheat crop is watered 4 times in a season. One of the constraints identified in C-DAP is lack of scientific water conservation and management. The agricultural plan for the district suggests provision of micro-irrigation system for

efficient water management with a total outlay of Rs 600 Crore for 5 years plan and Rs 235 Crore for training cum demonstration of water saving technology in paddy.

For domestic sub-sector, city of urban was surveyed and groundwater is the most prominent source for drinking purpose and other household chores. Major industries in the district are tobacco based industries, sugar mills, handicrafts, etc.

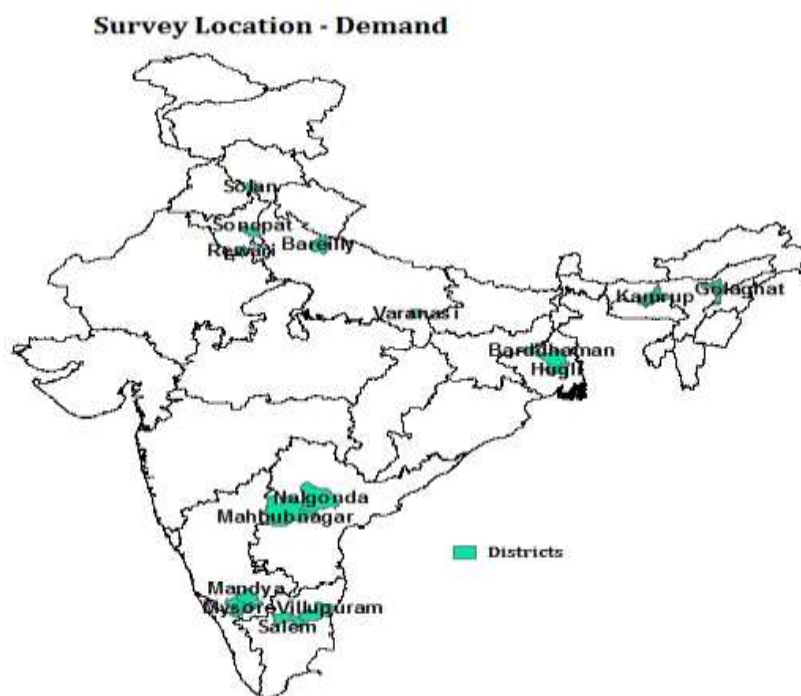

Figure 1.4 Survey locations for energy demand sectors

In Varanasi district a village was surveyed for the agriculture sector. The average land holding size ranges between 0.65 - 4 hectares. Paddy is the main crop of the region and is generally irrigated. Groundwater is the primary source of irrigation. Source of water for rural households is groundwater and it is abstracted through pump and stored in storage tanks of varying capacity. The pump was used for abstracting the water from 1 to 4 hours per day. The agricultural plan for the district suggests provision of micro-irrigation system for efficient water management with a total outlay of Rs 400 Crore for 5 years plan; Rs 125.60 Crore for training cum demonstration of ridge and furrow system of paddy cultivation and Rs 100 Crore for water harvesting, storage and utilization for irrigation. Poor water management and inadequate electricity for tube-well is few of the problems faced by the district.

In urban parts of the district both ground water (own bore-well) and housing development supply are the source of water. On an average pump is used for around 2 hours per day to abstract the groundwater and store it in the storage tanks. Major industries in the district are handicrafts, agriculture based industry etc.

In Haryana's Sonapat district the two main crops grown are wheat and Paddy. For irrigation purpose, farmers are mainly dependent on groundwater (Bore well) as the main source. In case of wheat crop, on an average 4 times irrigation are given and for paddy, 6 irrigations are given to keep field flooded. The duration of irrigation is in the range of 25-400 minutes/ha for both the crops. Poor water management has been identified as one of the

main issues in C-DAP of Sonipat district. The main source of water for domestic use is from town water supply and also from groundwater at some locations. In Rewari district, barley, mustard, wheat are the main crops and ground water and canal water are both the sources for irrigation, but groundwater is the dominant source. For drinking purpose in rural areas, groundwater is the main source. Declining groundwater is a major concern and for this C-DAP proposed adoption of strategies to take groundwater recharge.

In Himachal Pradesh, two districts (Solan and Shimla) were chosen for the survey. In district Solan, Solan city, Barog, Deogath and Chail were surveyed and in Shimla, Shimla city, Naldera, Mashobra and Baleah were surveyed. The main crops grown in these locations are wheat, maize, vegetables and flowers. In district Solan and Shimla agriculture is mainly rainfed but at some locations like Chail, lift irrigation is also done. The main source of irrigation is either pond (rain/surface water) or groundwater. For domestic water and energy consumption, households from rural and urban areas in Shimla and Solan districts were surveyed. The main source of water for domestic use is from Irrigation and Public Health Department Himachal Pradesh.

In Southern region, Telangana, Tamil Nadu and Karnataka were selected states for survey. In Telangana, Mahbubnagar district was one of the districts. In Mahbubnagar district, maize is the main crop grown by the farmers. Groundwater is the main source of irrigation and the crop is irrigated 8 times in a season. Another district surveyed was Nalgonda where paddy and sugarcane are the major crops and groundwater is the main source of irrigation. In Tamil Nadu's Villupuram district, three villages, Melpadi, Valavanur and Thanasingapalayam were surveyed for agriculture sub sector. The main crop grown in the villages are black gram and sugarcane. Most of the farmers are dependent on irrigation source for farming and the common irrigation source is groundwater. In Salem district, two villages (Reddymaniyakaranur and Elumathanoor) were surveyed for agriculture and domestic water use. The crop selected for this district was Jowar. The farmers are dependent on groundwater for irrigating their jowar crop. All farmers own irrigation pump sets and electricity is given free from the government. In Karnataka state, Mandya district, eight villages (T.M. Hosur, Tharasugutte, KalmatiDoddi, Koppa, Nembinayakanahalli, Methappanakoppala, Mahadeshwarapura and Neelanahalli) spread in four taluks (Srirangapatna, Mandya, Maddur and Pandavapura) were surveyed for agriculture and domestic water use. The crop selected for this district was sugarcane and sugarcane is an important crop in Mandya district. All farmers own irrigation pump sets and electricity is given free for around 6 hours by the government. All farmers practice flood irrigation method for sugarcane. The main source of drinking water for domestic use in rural areas is from a common water supply point in the village provided by the government. In some villages, there is one tap provided to each household. In Mysore district, six villages (Bommenahalli, Hosaagrahara, Devarajapuram, Tandavapura, Debur and Kadukola) spread in three taluks (K R Nagara, Nanjanagudu and Mysore) were surveyed for agriculture and domestic water use. The crop selected for this district was paddy.

In Eastern region the states of West Bengal and Assam were surveyed. In West Bengal, in Kolkata city, household survey regarding (urban) domestic water consumption in different part of the city, such as Salt Lake area, Tollygunge, Bansdroni, Shyambazar, etc. were done. Most of the places are connected to supply lines from city municipality. Most of the households have 500-2000 L basement sumps which receive water from city supply. This water is further pumped to overhead 500-1000 L water tanks. Per capita monthly water consumption is around 2400 Litres. Average household monthly water consumption is around 22000 Litres. In Hooghly district both rural and urban households were covered. For

urban households Serampore town was chosen. The town is supplied water from the Hooghly River. Average household size is 6; average tank size is 700 Litres. Average household monthly water consumption is around 10000 Litres. Farmers in the sample of agri-sector district vary from small-scale to mid-scale having land holdings of 0.4 to 4 hectares. Main source of water is groundwater and rain water stored in pumps. Some parts of the district occasionally get water from a canal link or from small rivers. Mainly paddy and potato are cultivated. Agricultural survey was also done in Burdwan districts in the villages Nabagram, Gangpur and Masagram. In this district there is paddy and potato cultivation. Water is mostly received from DVC canal.

Survey Location - Supply

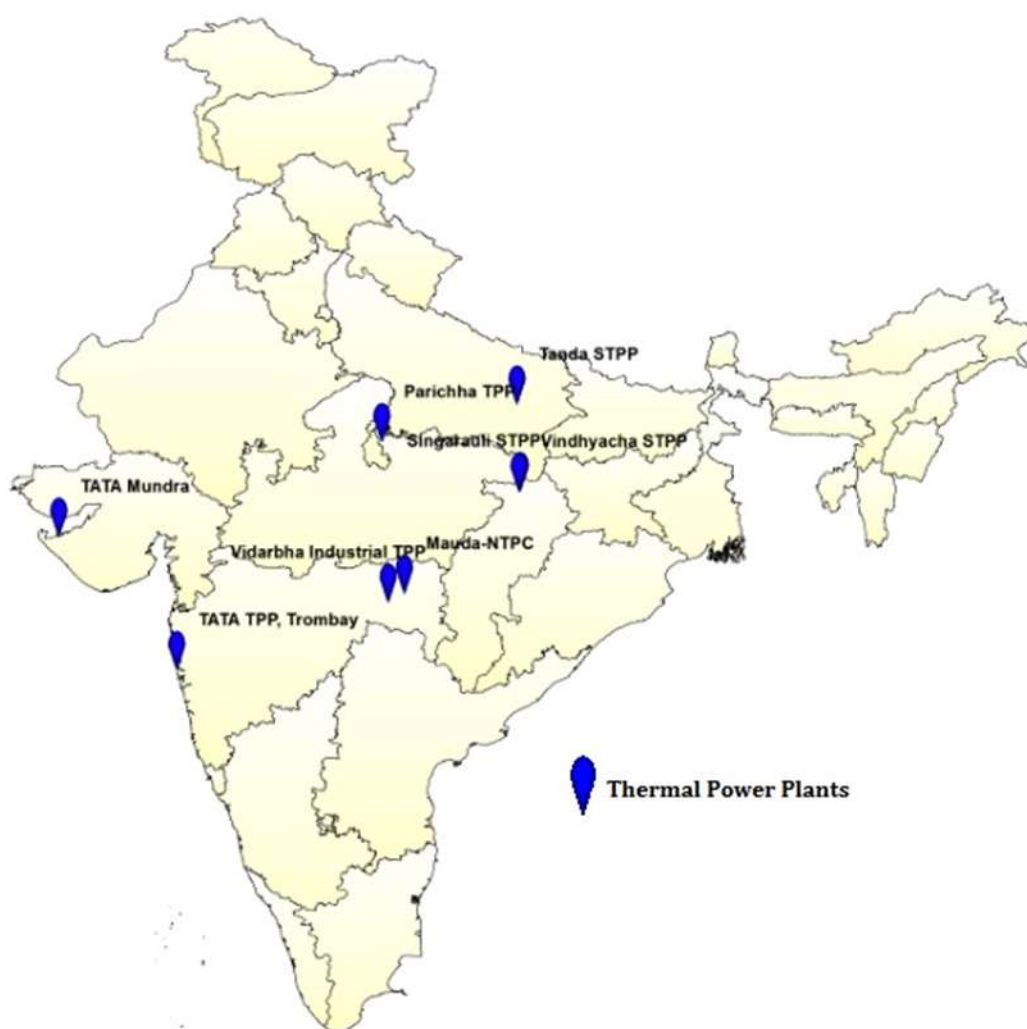

Figure 1.5 Survey map of energy supply (Thermal Power Plants) locations

Regional Assessment of Water Availability and its requirement

Western Region

Central Electricity Authority classifies the western region of the country as comprising of Gujarat, Maharashtra, Goa, Madhya Pradesh and Chhattisgarh. The region comprising of these states spreads over an area of 950891 km². However, considering the water flow pattern, rainfall scenarios and general understanding, we excluded Madhya Pradesh and Chhattisgarh and included Rajasthan as part of western region within our study. Thus, the western region comprises of Rajasthan, Gujarat, Maharashtra and Goa states, extending over an area of 8,50,264 km² covering almost one fourth of the country's total area.

Western Region



Figure 2.1: Location map of Western Region

Hydrological characteristics

Western region of the country is drained by the rivers like Sabarmati, Mahi, Narmada, Tapi, Godavari and Krishna. There are some ephemeral streams also in the western region, forming the inland drainage network within the state of Rajasthan and streams flowing west in Kutch and Saurashtra including Luni within Gujarat. Several small rivers flowing towards west between Tapi and Tadri also drain the western region. However, only Sabarmati and Mahi are the two major streams which originate within the region and lie within the western region. River Godavari and Krishna while originating within the region, drain mainly outside the western region, and only the lower catchment of rivers like Narmada and Tapi lies within the western region.

Rainfall distribution

Area weighted annual average rainfall in the western region is 776.46 mm, which is much below than the national annual average of 1187 mm. Within the region, rainfall varies significantly with western parts of Rajasthan covering 23% of the western region, receiving less than 300mm rainfall annually. Coastal parts of Maharashtra and Goa receive an annual average rainfall of more than 3000mm but cover only 4% of the total area of western region. Saurashtra and Kutch region occupying 13% of the region also receives scanty rainfall approximately 500mm. Rainfall in remaining 60% of the

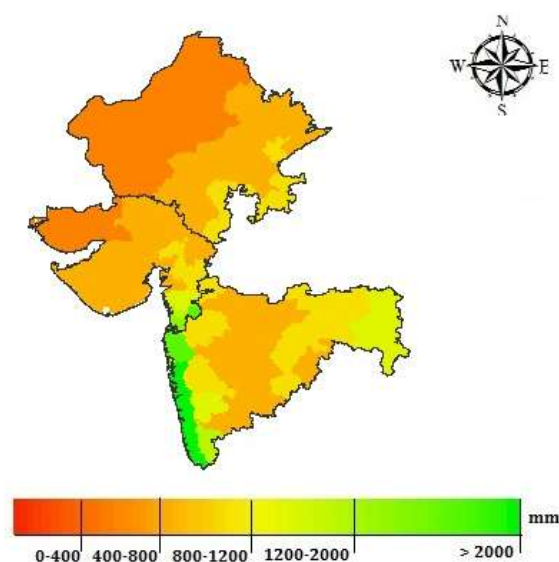

Figure 2.2: Rainfall distribution in Western region

region ranges between 650 - 1100mm.

Water availability in the region

Western region has 16.7% of total utilizable surface water resources of the country and 15.25% of net annual groundwater availability of the country. As such contribution of groundwater to the total water availability in the region is limited to 34% with major water supplies through the rivers draining the western region surface. Among the major states of the region, Maharashtra is richest in both available surface and groundwater resources with more than 50% share in the region. Rajasthan is the 2nd most abundant state followed by Gujarat with reference to surface water resources, however, net annual groundwater availability in Rajasthan is lesser than Gujarat (Figure 2.3). Per capita water availability in the region is 736 m³ which is less than half of the national per capita water availability.

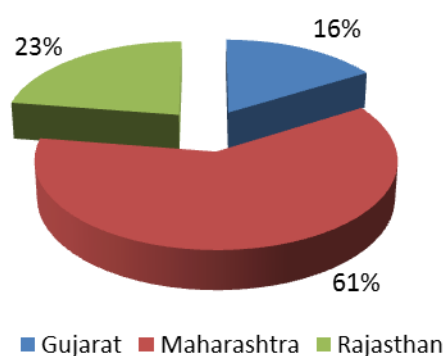

Figure 2.3A: Net surface water availability in states of the Western region

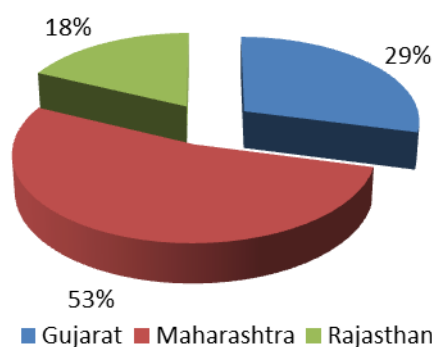

Figure 2.3B: Net groundwater availability in states of the Western region

Water demand in the region

1.1.1.5 Agricultural Water Demand

Almost 50% of the state's area equivalent to 4,46,350 km² is under crop cultivation. Rice and wheat are the dominant staple crops and cotton and sugarcane are the dominant cash crops. But area under cultivation of oil seeds, pulses and coarse cereals like Bajra, Ragi etc. is almost 80% of the total area under cultivation.

Intensity of irrigation among different states of the region varies significantly. Gujarat has 43% of its cultivated area under irrigation whereas Maharashtra has only 18.6%. As such, net area irrigated in western region is only 13.6 million hectares which is only 30% and much below the national average of 45%. Low irrigation intensity and dominance of less water consuming crops in the region, makes the total agricultural water requirement limited to 22% of the country's requirement for agricultural production.

Within the region, agricultural water requirement is highest for Maharashtra as compared to Gujarat and Rajasthan, mainly due to higher area under cultivation of rice and sugarcane in the state. Due to cropping pattern in Rajasthan, water requirement in the state is higher during rabi season as compared to kharif season, which is a distinct pattern as compared to other two states.

1.1.1.6 Domestic Water Demand

Total human population of the western region is 242.8 million with 40% people living in urban areas, and livestock population is close to 103 million. Total water demand for human and livestock consumption in the region is 6.8 BCM which is close to 11% of the total water demand in the region. With 46% share in total population of the region, Maharashtra has highest human water demand for both urban and rural areas. Water demand from rural areas of Rajasthan in almost double the water demand from its urban areas, however, urban water demand is 68% of the total human water demand for the region. Thus, while temporal distribution of water demand is almost uniform throughout the year, spatial distribution is highly uneven.

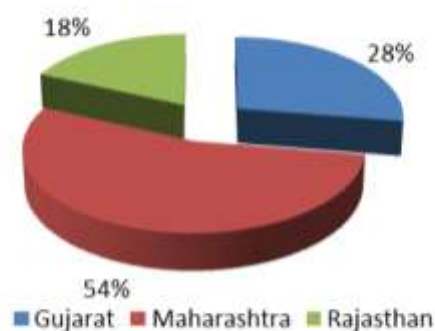

Figure 2.4A: Urban water demand in the western region

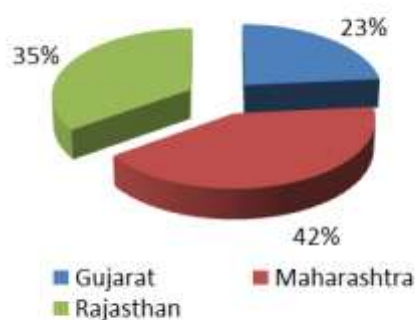

Figure 2.4B: Rural Water Demand in the western region

1.1.1.7 Industrial Water Demand

Western region especially the states of Maharashtra and Gujarat are among the highly industrialized states of the country. Total water consumption for major industries of the region viz., textile, pulp and paper, cement, fertilizer and iron and steel industry is found to be approximately 2 BCM which is 1/3rd of the domestic water demand. Among the industries, iron and steel industry located in Gujarat and Maharashtra are the biggest water guzzler with almost 75% of industrial water consumption in the western region. Among the states, Gujarat and Maharashtra consume about 47.5% and 44% of total industrial water consumption, respectively.

Water for energy production in the region

Western region is the top energy producer of the country, producing almost one third of total electricity in the country. 77% of electricity in the region is produced through non-renewable resources like coal and gas, contributing about 39% of total coal based electricity production in the country. Western region is also responsible for 73% onshore exploration of petroleum in the country and has 47.3% of country's oil refining capacity. The region is also credited with production of almost 25% of country's bio-fuel based energy.

Total water requirement for the production of energy in the western region is almost equivalent to its industrial water requirement. 87.5% of water for energy in the region is consumed for production of electricity and remaining for the exploration and refining of petroleum. With reference to water consumption for energy production, major states of the

region can be ranked as Maharashtra> Gujarat> Rajasthan, however, the top two states are responsible for consumption of almost 84% of total water.

Water stress in the region

Different sectoral water demands for the western region can be distributed as

Table 2.1: Sectoral Water Demand in Western Region

	Sectoral Water Demand	% Share in total
1	Agricultural	85.36%
2	Domestic	9.26%
3	Industrial	2.78%
4	Energy Production	2.60%

On an annual basis, total water demand for the region is almost 41% of its total water availability. 34% of total water availability is contributed by replenishable ground water and 66% by the surface water resources. As proportion of water demand against water available is between 40-80%, the region is categorized as 'High water stress region'.

Southern Region

Southern region of the country comprises of Karnataka, Kerala, Tamil Nadu and erstwhile Andhra Pradesh. The region comprising of these states spreads over an area of 6,38,000 km², equivalent to 20% of the country's surface area. Forming the southern part of Indian peninsula, the region is bounded by Arabian Sea in the west, Bay of Bengal in the east and Indian Ocean in the south. Due to proximity to these water bodies and equatorial zone, the region has a tropical climate. Deccan Plateau bordered by Western Ghats in west and Eastern Ghats in the east forms the major part of the southern region.

Hydrological characteristics

Southern region of the country is drained by rivers like Godavari, Krishna, Cauvery and Pennar. There are several small streams also which drain the coastal regions of Southern region. These small streams flowing towards Bay of Bengal are located between Mahanadi and Pennar river basins, and between Pennar river basin and Kanyakumari in Tamil Nadu. Together these east flowing rivers have a utilizable surface water potential of 29.6 BCM. Similarly, several small stream flowing towards Arabian Sea are located between Tadri in Karnataka and Kanyakumari. These west flowing small streams have a total utilizable surface water potential of 24.3 BCM. Total utilizable water potential of these small west and east flowing rivers is almost 39% of



Figure 2.5: Location map of Southern Region

the total surface water potential of the southern region. Cauvery and Pennar are the two major rivers originating within the region and draining about 21.4% of the area. However, water availability in these river basins is very less equivalent to only 18.6% of the total surface water potential of the southern region. Godavari and Krishna rivers originate in western region of the country but drain through southern region before meeting Bay of Bengal, and have 46% of their catchment draining 42% of the southern region mainly in Andhra Pradesh and Karnataka.

Rainfall distribution

Area weighted annual average rainfall in the Southern region is 1105 mm, which is almost equivalent to national annual average of 1187 mm. Within the region, coastal west consisting of Kerala and coastal Karnataka receives very high rainfall ranging between 3000-3500 mm, but covers only 9% of the southern region. This rainfall in coastal west provides water to the smaller west flowing streams located between Tadri and Kanyakumari. North interior parts of Karnataka and regions of Rayalseema in Andhra Pradesh are the driest regions with annual average rainfall about 700 mm and constituting 24% of the southern region. Further east, towards Bay of Bengal, annual rainfall ranges between 900-1100 mm.

Statewise Rainfall distribution in Southern Region

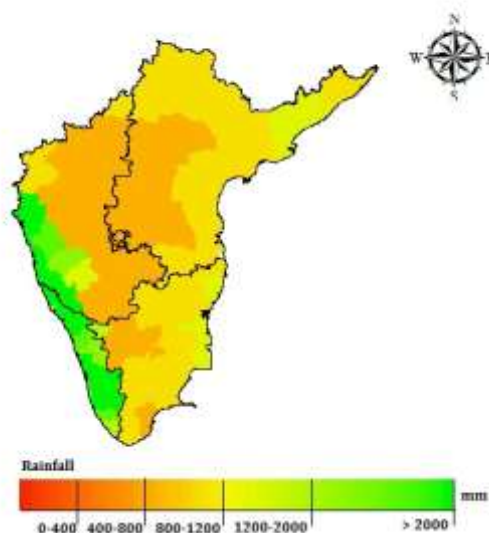

Figure 2.6: State-wise Rainfall distribution in Southern Region

Water availability in the region

Southern region has 19.6% of total utilizable surface water resources of the country and 18.2% of net annual groundwater availability of the country. As such contribution of groundwater to the total water availability in the region is limited to 34% with major water supplies through the rivers draining the Southern region surface. Among the major states of the region, Andhra Pradesh is richest in terms of both available surface and groundwater resources with more than 40% share in the region. Karnataka is the 2nd most abundant state followed by Tamil Nadu with reference to surface water resources, however, net annual groundwater availability in Karnataka is lesser than Tamil Nadu (Figure 2.7). Per capita water availability in the region is 843.5 m³ which is almost half of the national per capita water availability of 1588 m³. Among the states, per capita water availability is highest in Andhra Pradesh and least in Tamil Nadu. A similar trend is observed for per unit land water availability except Karnataka which has higher per capita water availability as compared to Kerala.

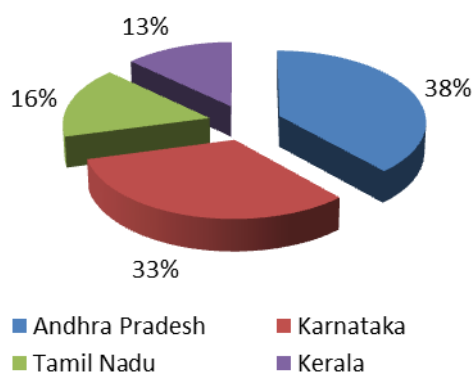

Figure 2.7A: State-wise distribution of Surface Water Availability in Southern region

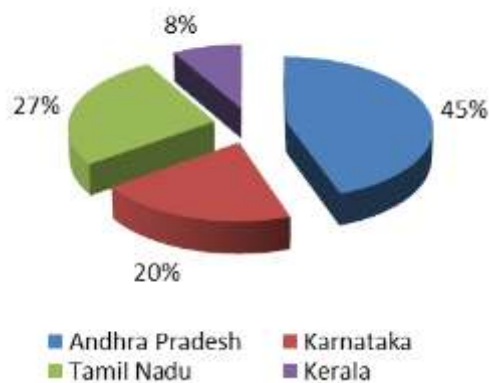

Figure 2.7B: State-wise distribution of Ground Water Availability in Southern region

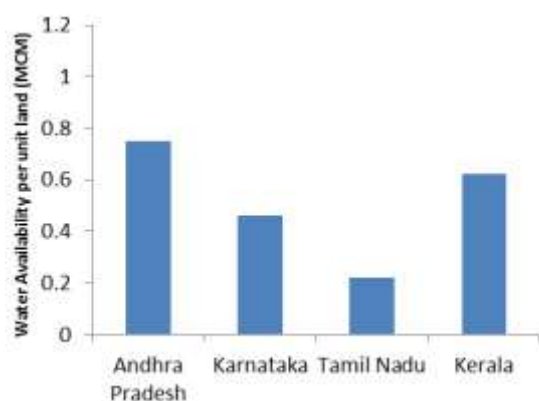

Figure 2.8A: State-wise per unit land water availability in Southern region

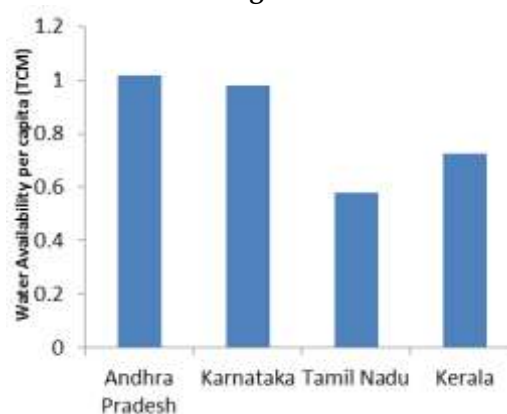

Figure 2.8B: State-wise per capita water availability in Southern region

Water demand in the region

1.1.1.8 Agricultural Water Demand

Almost 45% of the state's area equivalent to 2,79,537 km² is under crop cultivation. 75% of total cultivated area in southern region lies in Andhra Pradesh and Karnataka. Paddy is the most dominant crop in the region being grown in almost 1/3rd of agricultural land. Area under paddy cultivation in Andhra Pradesh is almost half of the total in the southern region. Other important crops of the region are Maize and coarse cereals – mainly being grown in Karnataka, and pulses and oil crops – mainly in Andhra Pradesh and Karnataka. Sugarcane is very common cash crop in Karnataka and Tamil Nadu being grown in 3% of total cultivated area. Area under cotton cultivation is almost 9% of the total cultivated area in southern region and is the primary cash crop in Andhra Pradesh.

Intensity of irrigation among different states of the region varies significantly. Ratio of net area irrigated to net crop area is maximum for Tamil Nadu followed by Andhra Pradesh and Karnataka, with least being in Kerala. As such, net area irrigated in Southern region is 11.1 million hectares which is 40% of total crop area and is below the national average of 45%. Paddy is the major crop under irrigation with 81% of its cropped area being irrigated, with as much as 92% of paddy area in Tamil Nadu being irrigated. Net irrigation water requirement in southern region is 60% of its total crop water requirement and is 15% of the

national water production.

Within the region, agricultural water requirement is highest for Andhra Pradesh and Tamil Nadu consuming almost 75% of total irrigation water. Water requirement for kharif season is higher in all the states except Tamil Nadu, where water requirement for Rabi season is higher.

1.1.1.9 Domestic Water Demand

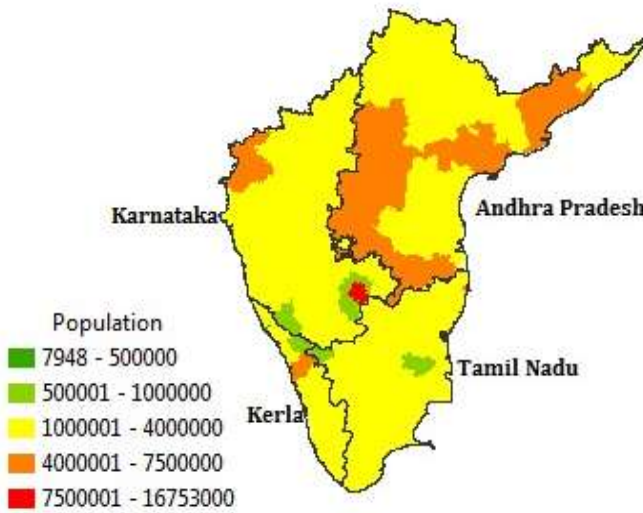

Figure 2.9: State-wise Population distribution in Southern Region

Total human population of the Southern region is 251.23 million with 41% people living in urban areas, and livestock population is close to 68 million. Total water demand for human and livestock consumption in the region is 7.23 BCM which is close to 12% of the total water demand in the region. Andhra Pradesh has highest population in the region, but due to higher level of urbanization, human water demand is highest in Tamil Nadu. Urban water demand is higher than rural water

demand in all the states, requiring about 70% of the total domestic water for the region. Thus, while temporal distribution of water demand is likely to be almost uniform throughout the year, spatial distribution is concentrated in urban areas.

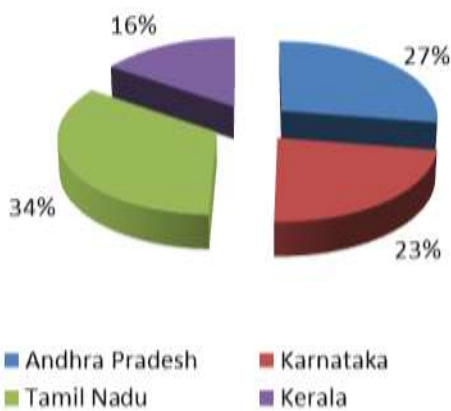

Figure 2.10A: Urban water demand in the Southern region

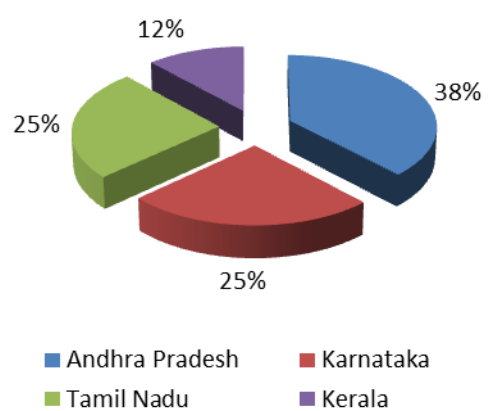

Figure 2.10B: Rural Water Demand in the Southern region

1.1.1.10 Industrial Water Demand

Southern region is among the most industrialized regions of the country. Tamil Nadu is famous for manufacturing auto and textile production, Karnataka is known as the

Information Technology Hub, Andhra Pradesh has a flourishing Biotechnology and Pharmaceutical Industry, while Kerala and Puducherry are famous for tourism. Total water consumption for major industries of the region viz., textile, pulp and paper, cement, fertilizer and iron and steel industry is found to be approximately 2.5 BCM which is around 1/3rd of the domestic water demand. Among the industries, iron and steel industry located in Karnataka and Andhra Pradesh is the biggest water guzzler with almost 60% of industrial water consumption in the Southern region. Among the states, Karnataka and Andhra Pradesh consume about 36% and 33% of total industrial water consumption in the region.

Water for energy production in the region

Southern region is the 3rd largest producer of electricity in the country, producing almost 26% of total electricity in the country. Simultaneously, southern region is leading producer of electricity through renewable resources and nuclear fuel. However, 57.5% of electricity in the region is produced through non-renewable resources like coal, gas and diesel, contributing about 21% of total coal based electricity production in the country. Southern region is also responsible for 3% onshore exploration of petroleum in the country and has 22% of country's oil refining capacity. The region is also credited with production of almost 21% of country's bio-fuel based energy.

Total water requirement for the production of energy in the Southern region is almost 50% of its industrial water requirement. 94% of water for energy in the region is consumed for production of electricity and remaining for the exploration and refining of petroleum. With reference to water consumption for electricity production, major states of the region can be ranked as Andhra Pradesh > Tamil Nadu > Karnataka > Kerala, however, the top two states are responsible for consumption of almost 73% of total water.

Water stress in the region

Different sectoral water demands for the western region can be distributed as

Table 2.2: Sectoral Water Demand in Southern Region

	Sectoral Water Demand	% Share in total
1	Agricultural	82.39
2	Domestic	11.69
3	Industrial	3.85
4	Energy Production	2.07

On an annual basis, total water demand for the region is almost 30% of its total water availability. 34.3% of total water availability is contributed by replenishable ground water and remaining by the surface water resources. As proportion of water demand against water available is between 20-40%, the region can be categorized as 'medium to high' water stress region.

Central Region

Central Electricity Authority classifies the western region of the country as comprising of Gujarat, Maharashtra, Goa, Madhya Pradesh and Chhattisgarh. The region comprising of these states spreads over an area of 950891 km². However, considering the water flow pattern, rainfall scenarios and general understanding, we excluded Madhya Pradesh and Chhattisgarh from the western region and include them into a separate central region. Thus, Central region of the country comprising of Madhya Pradesh and Chhattisgarh states spreads over an area of 4,42,841 km², equivalent to 13.5% of the country's surface area. Forming the central part of the country, the region is completely land locked bounded by other four regions of the country. Deccan Plateau bordered by Western Ghats in west and Eastern Ghats in the east forms the major part of the Central region.

Hydrological characteristics

Central region of the country is drained by 7 major rivers - Ganga, Narmada, Tapi, Mahi, Godavari, Mahanadi and Brahmani - Baitarni. Northern part of the region forms the southern part of Ganges basin, and southern part of the region forms the parts of Godavari basin. The region is also credited with the origin of three major west flowing rivers of the country – Narmada, Tapi and Mahi, forming approximately 22.5% of the region. East flowing river – Mahanadi, draining 17% of the area also originates within the central region. Southern tributaries of River Ganga like Chambal, Betwa and Son originate from the region and form 46% of its area. However, Narmada is most important river of the region with almost 85% of its catchment lying within the region and flowing through some of the most densely populated regions of the region.



Figure 2.11: Location map of Central

Rainfall distribution

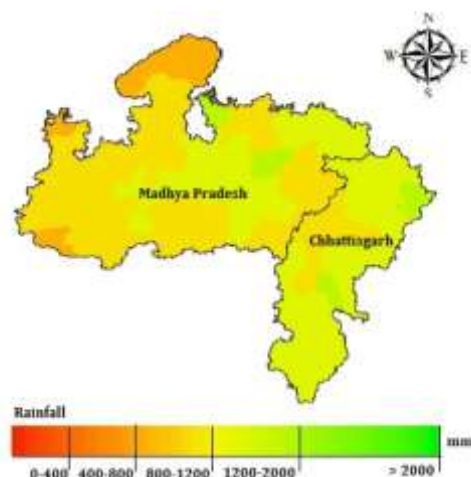

Figure 2.12: State-wise Rainfall distribution in Central Region

Area weighted annual average rainfall in the Central region is 1100 mm, which is almost equivalent to national annual average of 1187 mm. Overall, spatial distribution of rainfall with the region is almost uniform but the western part and the regions of Bundelkhand are slightly drier than the eastern parts. coastal west consisting of Kerala and coastal Karnataka receives very high rainfall ranging between 3000-3500 mm, but covers only 9% of the Central region.

Water availability in the region

Central region has 18% of total utilizable surface

water resources of the country and 11.3% of net annual groundwater availability of the country. As such contribution of groundwater to the total water availability in the region is limited to 25% with major water supplies through the rivers draining the central region surface. Among the major states of the region, Madhya Pradesh is richest in both available surface and groundwater resources with almost 70% share in the region (Figure 2.13). In fact, Madhya Pradesh is the state with maximum utilizable surface water potential among all the states of the country. Also, the region has least net annual ground water availability among all the regions of the country. Proportion of surface and ground water availability in the region is 3:1. 42% and 23% of total surface water availability in the central region is ensured by river Ganga and Narmada, respectively. Per capita water availability in the region is very high and is atleast 10-25% higher than the national per capita water availability of 1588 m³. Among the states, per capita water availability is highest in Chhattisgarh followed by Madhya Pradesh. However, per unit land water availability is higher in Madhya Pradesh than in Chhattisgarh (Figure 2.14).

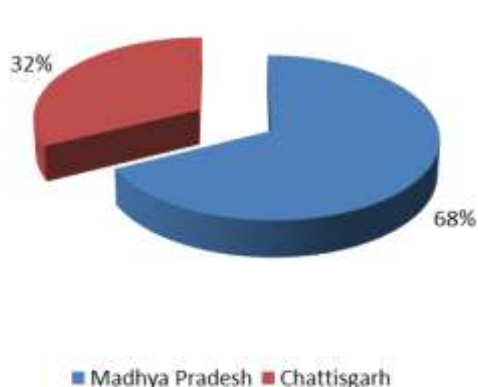

Figure 2.13A: State-wise distribution of Surface Water Availability in Central region

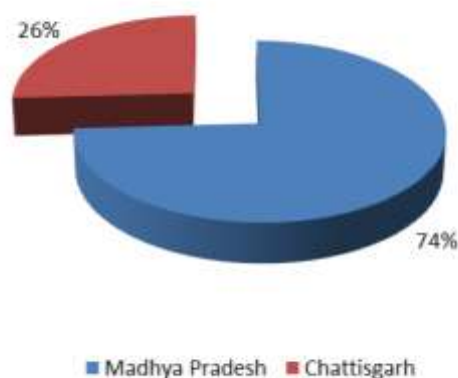

Figure 2.13B: State-wise distribution of Ground Water Availability in Central region

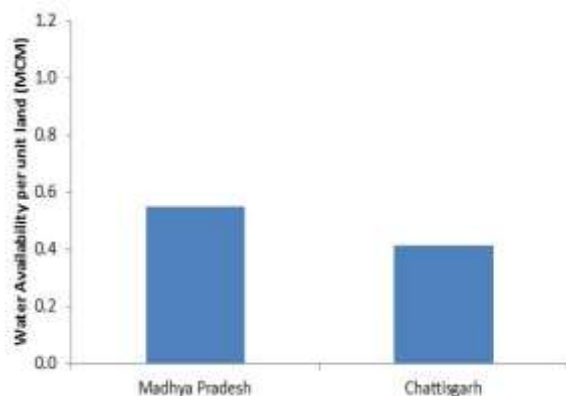

Figure 2.14A: State-wise per unit land water availability in Central region

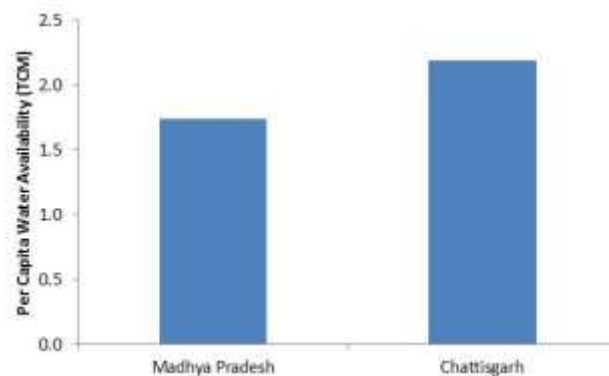

Figure 2.14B: State-wise per capita water availability in Central region

Water demand in the region

1.1.1.11 Agricultural Water Demand

Almost 44% of the region's area equivalent to 1,96,500 km² is under crop cultivation. 76% of total cultivated area in Central region lies in Madhya Pradesh. Paddy and wheat are the most dominant crop in the region being grown in almost half of the agricultural land. Area under paddy cultivation in Chhattisgarh is almost 75% of the total paddy cultivation area in the Central region. On the contrary, area under wheat cultivation in Madhya Pradesh is almost 98% of the total wheat cultivation area in the region. Central region is among the leading producers of pulses and oil crops in the country with almost 20% of the national area under the two crops lying within this region.

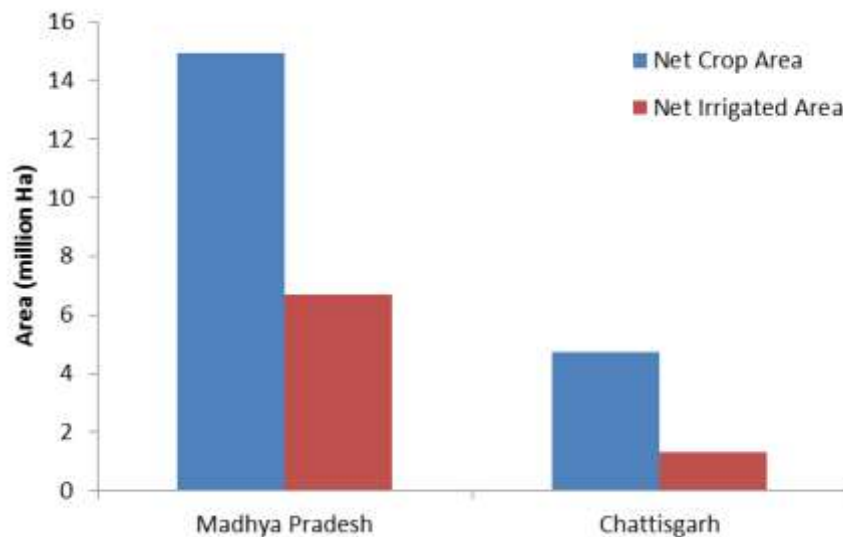

Figure 2.15: Net Crop Area and Net Irrigated Area in Central Region

Ratio of net area irrigated to net crop area is higher for Madhya Pradesh than Chhattisgarh. As such, net area irrigated in Central region is 8 million hectares which is 41% of total crop area and is below the national average of 45%. Wheat is the major crop under irrigation with

82% of its cropped area being irrigated. Paddy cultivation in Chhattisgarh is primarily rainfed and only 34% of its paddy area is being irrigated. Net irrigation water requirement in Central region is 40% of its total crop water requirement and is 11% of the national water requirement for 13% of national area under irrigation for agricultural production.

Within the region, irrigation water requirement for Madhya Pradesh is almost 5 times the requirement for Chhattisgarh consuming almost 82% of total irrigation water. Water requirement for rabi season is higher than the kharif season, due to dominance of wheat cultivation in Madhya Pradesh.

1.1.1.12 Domestic Water Demand

Total human population of the Central region is 98.17 million with only 26.5% people living in urban areas, and livestock population is close to 51 million. Total water demand for human and livestock consumption in the region is 2.34 BCM which is close to 5.6% of the total water demand in the region. Madhya Pradesh has almost 3 times the population of Chhattisgarh, and so human water demand is also higher in the state. Urban water demand is higher than rural water demand in Madhya Pradesh but it is almost same for Chhattisgarh.

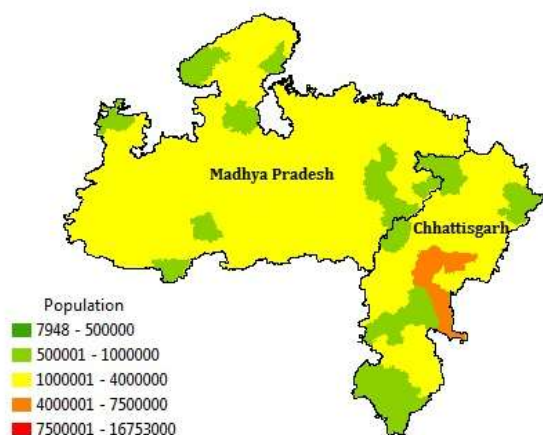

Figure 2.16: State-wise Population distribution in Central Region

1.1.1.13 Industrial Water Demand

Central region is among the least industrialized regions of the country. Major industries of the region viz., textile, pulp and paper, cement, fertilizer are located in Madhya Pradesh and are responsible for consuming 29% of total industrial water. Iron and steel industry located in Chhattisgarh is the biggest water guzzler with almost 71% of industrial water consumption in the Central region. This also makes Chhattisgarh as the biggest consumer of industrial water in the region.

Water for energy production in the region

Madhya Pradesh and Chhattisgarh produce almost 11% of total electricity in the country. Simultaneously, central region is also produces about 8% of country's renewable electricity. However, 78.5% of electricity produced in the region is through non-renewable resources like coal and gas, contributing about 15% of total coal based electricity production in the country. There is only 1 oil refinery located in the central region with the refining capacity of 6 million tons. The region is also credited with production of almost 7% of country's bio-fuel based energy. Total water requirement for the production of energy in the Central region is more than its industrial water requirement, but almost 1/3rd of its domestic water requirement.

Water stress in the region

Different sectoral water demands for the western region can be distributed as

Table 2.3: Sectoral Water Demand in Central Region

	Sectoral Water Demand	% Share in total
1	Agricultural	91.2
2	Domestic	5.6
3	Industrial	1.5
4	Energy Production	1.7

On an annual basis, total water demand for the region is only 23% of its total water availability. 25% of total water availability is contributed by replenishable ground water and remaining by the surface water resources. As proportion of water demand against water available is close to 20%, the region can be categorized as 'low to medium' water stress region.

Eastern Region

Eastern region of the country comprises of Bihar, Jharkhand, West Bengal and Odisha. The region comprising of these states spreads over an area of 4,24,810 km², equivalent to 13% of the country's surface area. The region is bounded by Himalayan Mountains in the north and Bay of Bengal towards south east adjoining West Bengal and Orissa. The region lies in the humid-subtropical zone, and experiences hot summers from March to June. Jharkhand and Orissa are mineral rich states of the country while Bihar and West Bengal have fertile alluvial soil of the Gangetic plains.

Hydrological characteristics

Eastern region of the country is drained by rivers like Ganga, Mahanadi, Brahmaputra, Subarnrekha, Brahmani-Baitarni, and Godavari. Also, there are small streams which drain the coastal regions of Eastern region. These small streams flowing towards Bay of Bengal are located in Odisha south of Mahanadi river. Largest area of the region lies in the Ganga basin forming almost 55% of the eastern region and contributing to 58% of the utilizable surface water potential of the region. Subarnrekha and Brahmani-Baitarni are smaller rivers but lie almost within the eastern region and drain almost 20% of the region contributing about 18% of the region's surface water potential. Mahanadi originating in the central region, drains through eastern region before meeting Bay of Bengal and has almost 50% of its catchment area in this region contributing to 18% of its surface water potential.

Rainfall distribution

Area weighted annual average rainfall in the Eastern region is about 1470 mm, which is higher than the national annual average of 1187 mm. Within the region, except the southern Bihar and parts of Jharkhand, rainfall is plenty. Sub-Himalayan West Bengal in the north-eastern part of the region receives 2700 mm rainfall, annually. Significant rainfall in the Jharkhand leads to the origin of Subarnrekha and Brahmani-Baitarni rivers, with their average water resources potential of 41 BCM, however, considering the topography and other geographical factors, only 60% of this water can be utilized.

Water availability in the region

Eastern region has 19% of total utilizable surface water resources of the country and 20.3% of net annual groundwater availability of the country. As such contribution of groundwater to the total water availability in the region is limited to 36% with major water supplies through the rivers draining the Eastern region surface. Among the states, Odisha is richest in



Figure 2.17: Location map of Eastern

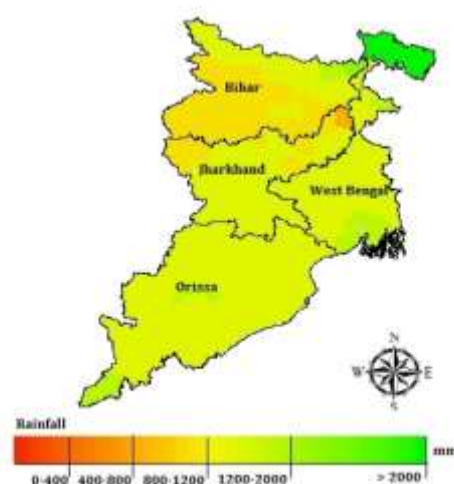

Figure 2.18: State-wise Rainfall distribution in Eastern Region

available surface water resources with more than 34% share in the region. West Bengal, Bihar and Jharkhand follow the sequence of availability quantum. However, net annual groundwater availability is very high in West Bengal and Bihar constituting 70% of the region's potential (Figure 2.19). Eastern region is the most populated region of the country and inspite of high water availability in the region, its per capita water availability is almost half of the national per capita water availability of 1588 m³. Among the states, per capita water availability is highest in Odisha and least in Bihar. With reference to the water availability per unit land, West Bengal and Bihar have higher proportion as compared to Odisha and Jharkhand.

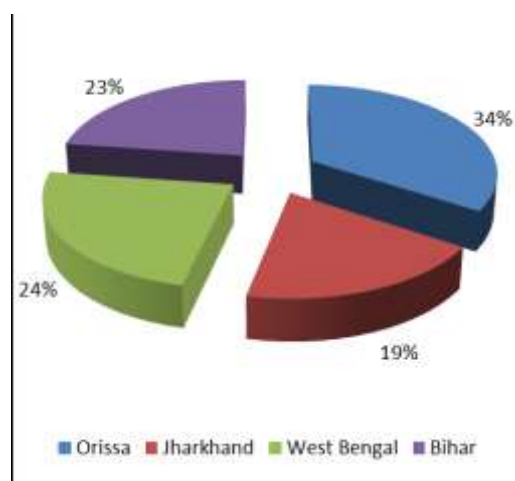

Figure 2.19A: State-wise distribution of Surface Water Availability in Eastern region

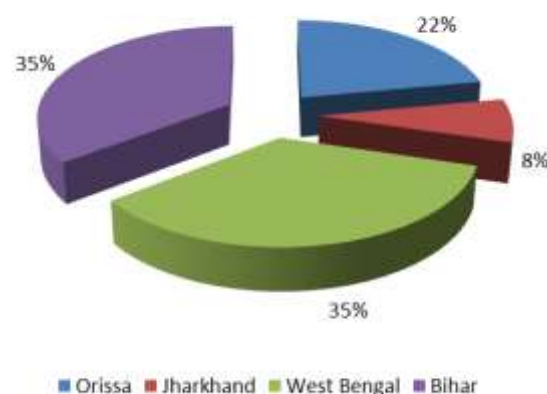

Figure 2.19B: State-wise distribution of Ground Water Availability in Eastern region

Water demand in the region

1.1.1.14 Agricultural Water Demand

Almost 42% of the state's area equivalent to 1,76,759 km² is under crop cultivation. Cultivated area in eastern region is almost uniformly distributed among Bihar, West Bengal and Odisha with Jharkhand sharing only 8%. Paddy is the most dominant crop in the region being grown in almost 75% of agricultural land. Area under paddy cultivation in Odisha and West Bengal is almost 72% of the total in the eastern region. Almost 80% of area under wheat cultivation lies in Bihar. Pulses also make an important crop under cultivation being grown in almost all the states.

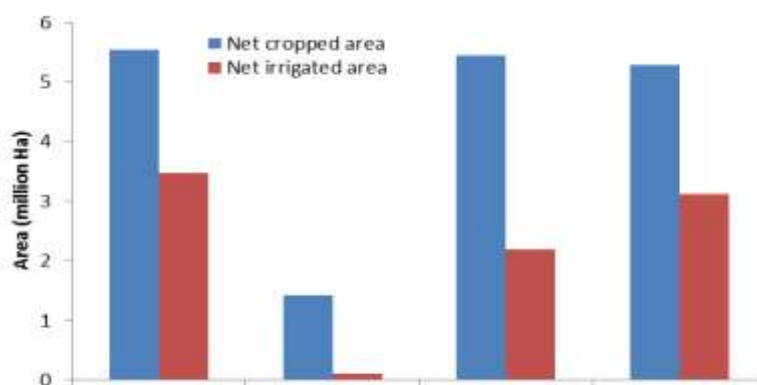

Figure 2.20: Net crop area and Net irrigated area in Eastern Region

Ratio of the net area irrigated to net crop area is maximum for Bihar and West Bengal, with least being in Jharkhand. Only 8% of the area under cultivation in Jharkhand is being irrigated. As such, net area irrigated in the Eastern region is 8.8 million hectares which is 50% of the total crop area and is above the national average of 45%. Paddy is the major crop under irrigation with 76% of its cropped area being irrigated, with as much as 68% of paddy area in Bihar being irrigated. Net irrigation water requirement in eastern region is 56% of its total crop water requirement and is 15% of the national water requirement for 14% of national area under irrigation for agricultural production.

Within the region, agricultural water requirement is highest for Bihar and West Bengal consuming almost 80% of total irrigation water. Water requirement for kharif season is higher for Odisha and West Bengal but in Bihar, water requirement is higher during rabi season due to wheat cultivation in the state.

1.1.1.15 Domestic Water Demand

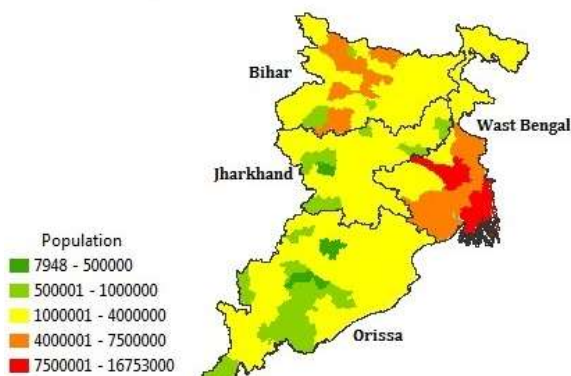

Figure 2.21: State-wise Population distribution in Eastern Region

Total human population of the Eastern region is 270.33 million with only 21% people living in urban areas, and livestock population is close to 98.5 million. Total water demand for human and livestock consumption in the region is 5.88 BCM which is close to 10% of the total water demand in the region. Bihar has highest population in the region, but due to higher level of urbanization, human water demand is highest in West Bengal. Urban water demand is less than rural water demand in Bihar and Odisha but in West Bengal, it is 61% of the domestic water demand for the state. For the region, rural water demand is 53% of the total domestic water demand.

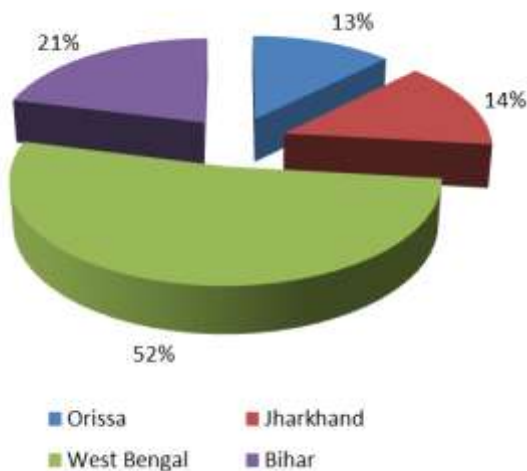

Figure 2.22A: Urban water demand in the Eastern region

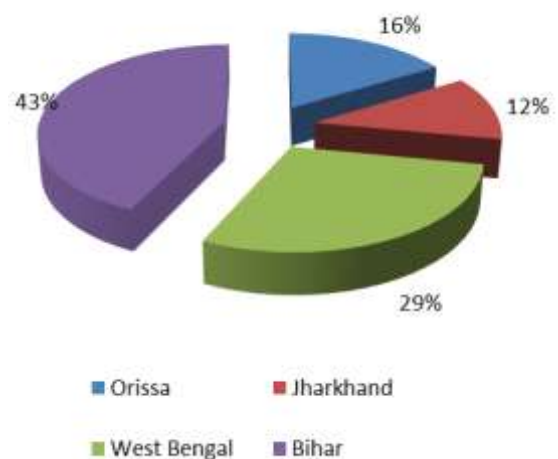

Figure 2.22B: Rural Water Demand in the Eastern region

1.1.1.16 Industrial Water Demand

Eastern region is among the least industrialized regions of the country. But iron and steel industry is very prominent in states of Odisha, Jharkhand and West Bengal. Iron and steel industry constitutes for 86% of total industrial water consumption in the region. Among the states, Jharkhand is the biggest consumer of industrial water followed by Odisha and West Bengal. Bihar has some cement industry and its industrial water requirement is negligible.

Water for energy production in the region

Eastern region produces almost 10% of total electricity in the country. However, 86% of electricity in the region is produced through non-renewable resources like coal and gas, contributing about 16% of total coal based electricity production in the country. Eastern region has 12% of country's oil refining capacity and produces almost 8.5% of country's bio-fuel based energy.

Total water requirement for the production of energy in the Eastern region is almost 50% of its industrial water requirement. 94% of water for energy in the region is consumed for production of electricity and remaining for the refining of petroleum. With reference to water consumption for electricity production, major states of the region can be ranked as West Bengal> Orissa> Jharkhand> Bihar, however, the top two states are responsible for consumption of almost 60% of total water.

Water stress in the region

Different sectoral water demands for the western region can be distributed as

Table 2.4: Sectoral Water Demand in Eastern Region

	Sectoral Water Demand	% Share in total
1	Agricultural	82.5
2	Domestic	9.7
3	Industrial	5.6
4	Energy Production	2.2

On an annual basis, total water demand for the region is almost 30% of its total water availability. 34.3% of total water availability is contributed by replenishable ground water and remaining by the surface water resources. As proportion of water demand against water available is between 20-40%, the region can be categorized as 'medium to high' water stress region.

Northern Region

Northern region of the country comprises of Jammu and Kashmir, Himachal Pradesh, Punjab, Haryana, Uttarakhand and Uttar Pradesh. The region comprising of these states spreads over an area of more than 6.5 lakh km², equivalent to 20% of the country's surface area. Forming the Northern part of Indian peninsula, the region is bounded by Arabian Sea in the west, Bay of Bengal in the east and Indian Ocean in the south. Due to proximity to these water bodies and equatorial zone, the region has a tropical climate. Deccan Plateau bordered by Western Ghats in west and Eastern Ghats in the east forms the major part of the Northern region.



Figure 2.23: Location map of Northern Region

Hydrological Characteristics

Northern region of the country is drained by mighty rivers like Indus and Ganga. Total area of the northern region is shared by Indus and Ganges river system as 47% and 53%, respectively. The Gangetic plains are mostly divided into three parts, Upper Ganga plains, Middle Ganga plains and Lower Ganga plains. The Upper Ganga plain lying approximately between the Yamuna in the west covers the parts of Uttarakhand and Uttar Pradesh, and lies entirely within the Northern region. The Middle Ganga Plain is the largest among the three plains of river Ganga, and covers eastern parts of Uttar Pradesh. Within northern region, Indus basin spreads over the states of Jammu & Kashmir, Himachal Pradesh, Punjab, and parts of Haryana, besides Union Territory of Chandigarh. Together, Indus and Ganga are responsible for making 32% of country's average water resources potential, however, all of this potential does not lie within the northern region. Almost all the rivers draining northern region originate from snow fed mountain catchments in Himalayas and are perennial in nature with year round availability of water in them.

Rainfall distribution

Area weighted annual average rainfall in the Northern region is 1074 mm, which is almost equivalent to national annual average of 1187 mm. Within the region, Uttarakhand and Himachal Pradesh receives maximum rainfall ranging between 1300-1600 mm, but covers only 15% of the Northern region. This rainfall in northern mountains provides water to the rivers like Indus and Ganga. Snow fall and glacier melting from the higher reaches of northern region also add to the total water availability in the region. Haryana and Punjab in the region are the driest states receiving rainfall in the range of 500-700 mm. Within Uttar Pradesh, eastern part is wet as compared to western parts of the state



Figure 2.24: Statewise Rainfall distribution in Northern region

Water availability in the region

Studied parts of Northern region has 13% of total utilizable surface water resources of the country and is the 2nd least abundant region among all the regions of the country. But, net annual groundwater availability of the region is 26% of the total availability in the country, and the region ranks as the most abundant among all the regions. As such contribution of groundwater and surface water to the total water availability in the region is almost 50%. Among the major states of the region, Uttar Pradesh is richest in both available surface and groundwater resources with more than 64% share in the region. Uttarakhand and Punjab are the 2nd most abundant states followed by Himachal Pradesh and Haryana and with reference to surface water resources, however, net annual groundwater availability in Himachal Pradesh is much lesser than Haryana (Figure 2.25). Total water availability in Haryana is higher than Himachal Pradesh due to contribution of its ground water resources. Per capita water availability in the region is 738 m³ which is almost half of the national per capita water availability of 1588 m³. Among the states, per capita water availability is highest in Himachal Pradesh and least in Haryana and Delhi. While per capita water availability in Uttar Pradesh is below average, per unit land water availability is highest in state, followed by Uttarakhand and Punjab. Similarly, Himachal Pradesh with above average per capita water availability, its per unit land water availability is least among all the states.

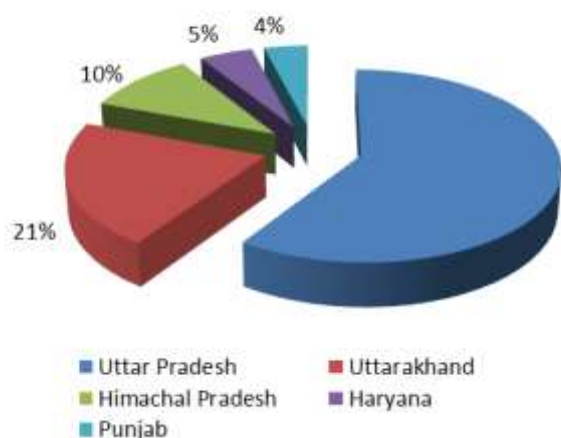

Figure 2.25A: State-wise distribution of Surface Water Availability in Northern region

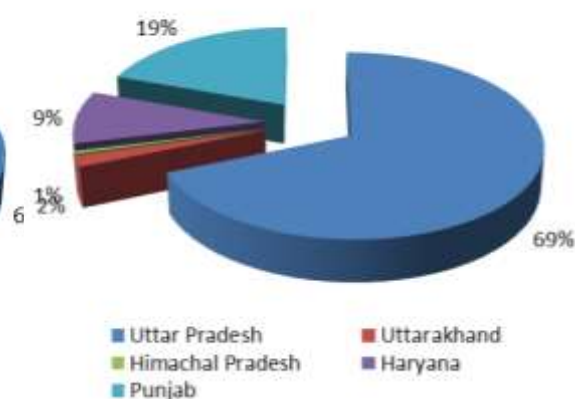

Figure 2.25B: State-wise distribution of Ground Water Availability in Northern region

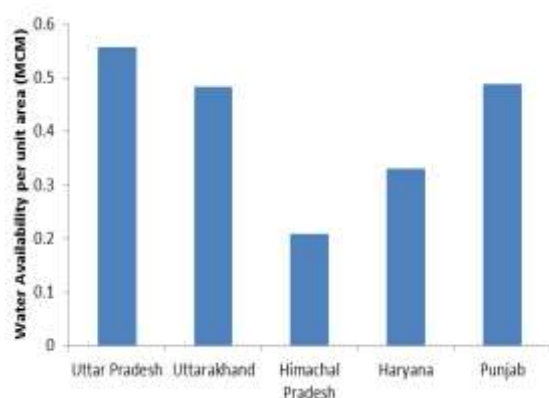

Figure 2.25C: State-wise per unit land water availability in Northern region

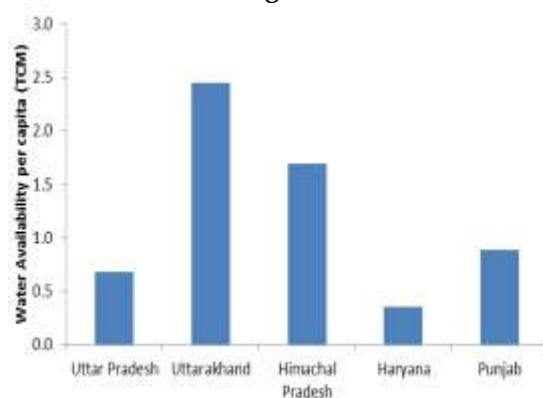

Figure 2.25D: State-wise per capita water availability in Northern region

Water demand in the region

1.1.1.17 Agricultural Water Demand

Almost 37% of the region's area equivalent to 2,48,793 km² is under crop cultivation. 67% of total cultivated area in Northern region lies in Uttar Pradesh. Cropping intensity in the region is equivalent to 163% with almost every land being sown twice in a year in states like Punjab and Haryana. Wheat is the most dominant crop in the region being grown in almost 2/3rd of agricultural land. Uttar Pradesh is the leading cultivator of paddy with almost half of the total paddy area in the Northern region. Other important crops of the region are Maize, coarse cereals, pulses and oil crops – mainly being grown in Uttar Pradesh. Sugarcane is very common cash crop in the northern region with maximum area under sugarcane cultivation in the country. Cotton is another important cash crop being grown mainly in Punjab and Haryana.

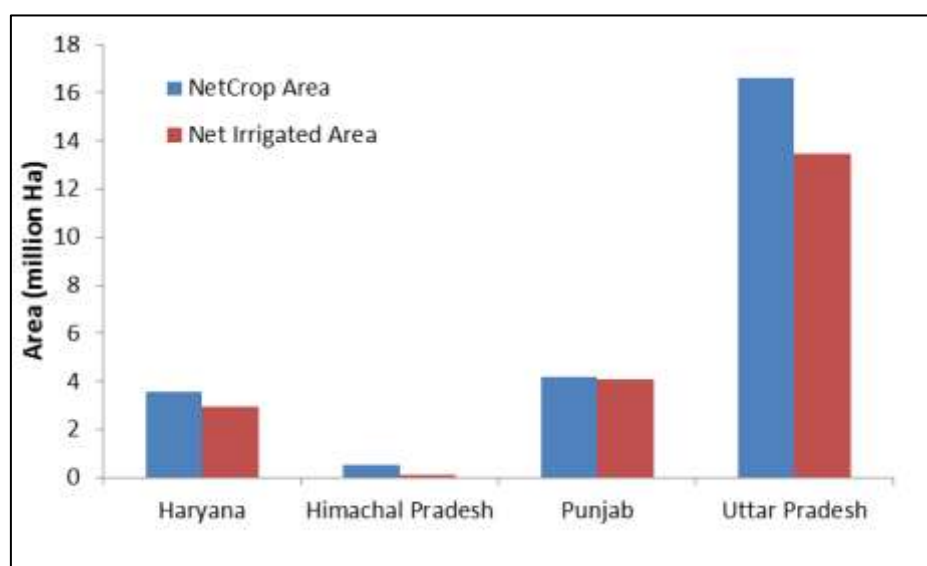

Figure 2.26: Net crop area and Net irrigated area in Northern Region

Net area irrigated in Northern region is 20.6 million hectares and ratio of net area irrigated to net crop area is 83% for northern region which is maximum among all the regions. Punjab has almost 97% of its net crop area being irrigated, followed closely by Haryana and Uttar Pradesh. Wheat is the major crop under irrigation with almost 95% of its cropped area being irrigated. Sugarcane is also a major crop under irrigation with almost all of its cropped area being irrigated. Paddy is being cultivated through irrigation in Punjab and Haryana. Due to high irrigation intensity, net irrigation water requirement in Northern region is 88% of its total crop water requirement and is 41% of the national water requirement for one third of national area under irrigation for agricultural production.

Within the region, agricultural water requirement is highest for Uttar Pradesh consuming almost 50% of total irrigation water. Water requirement for kharif season is higher in all the states than for Rabi season.

1.1.1.18 Domestic Water Demand

Total human population of the Northern region is 299.18 million with 29% people living in urban areas, and livestock population is close to 83 million. Total water demand for human and livestock consumption in the region is 6.84 BCM which is close to 5% of the total water

demand in the region. Uttar Pradesh has highest population in the region and consumes almost 65% of total domestic water in the region. Urban water demand is higher than rural water demand in all the states, except Uttar Pradesh, requiring about 58% of the total domestic water for the region.



Figure 2.27: State-wise Population Distribution in Northern Region

1.1.1.1 Industrial Water Demand

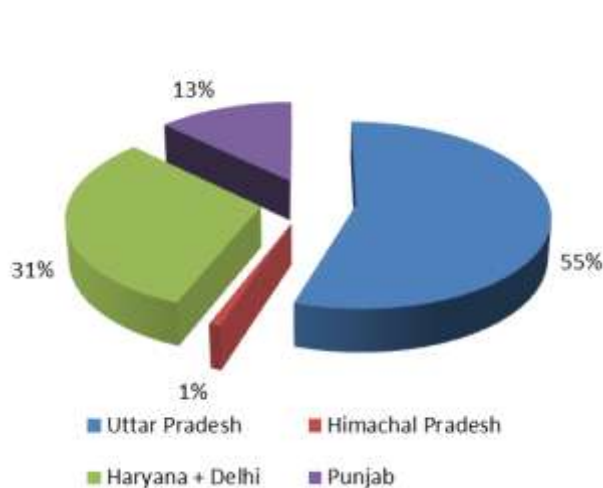

Figure 2.28A: Urban water demand in the Northern region

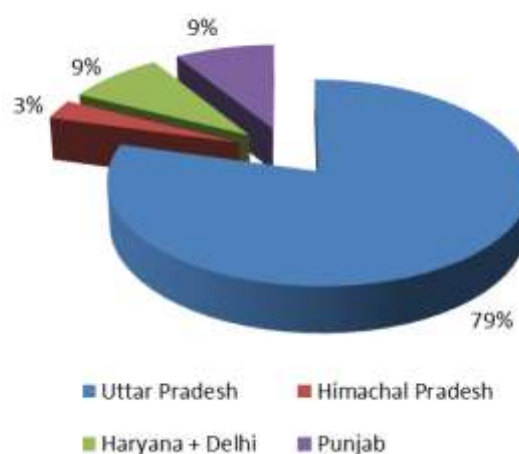

Figure 2.28B: Rural Water Demand in the Northern region

Northern region is moderately industrialized with pulp and paper, cement and textile industry dominating the landscape. Total water consumption for major industries of the region is found to be less than 1 BCM and is even equivalent to only 10% of the domestic water demand. Among the industries, textile industry of Punjab is the biggest water guzzler within the region consuming almost 1/3rd of total industrial water in the region. Among the states, Punjab and Uttar Pradesh consume about 35% and 33% of the total industrial water consumption in the region.

Water for energy production in the region

Northern region is the 2nd largest producer of electricity in the country, producing almost 26% of total electricity in the country. Simultaneously, Northern region is the leading producer of electricity through hydropower dams. However, 64% of electricity in the region is produced through non-renewable resources like coal and gas, contributing about 24.6% of total coal based electricity production in the country. Northern region is also responsible for 13.5% of country's oil refining capacity. Northern region leads the country in production of bio-fuel based energy generating almost 34% of the total.

Total water requirement for the production of energy in the Northern region is almost double of its industrial water requirement. 98% of water for energy in the region is consumed for production of electricity and remaining for the refining of petroleum. With reference to water consumption for electricity production, major states of the region can be ranked as Uttar Pradesh> Haryana> Punjab. These three states are responsible for consumption of almost 97% of total water.

Water stress in the region

Different sectoral water demands for the western region can be distributed as

Table 2.5: Sectoral Water Demand in Northern Region

	Sectoral Water Demand	% Share in total
1	Agricultural	93.9
2	Domestic	4.8
3	Industrial	0.5
4	Energy Production	0.8

On an annual basis, total water demand for the region is almost 70% of its total water availability. 49.3% of total water availability is contributed by replenishable ground water and remaining by the surface water resources. As proportion of water demand against water available is between 40-80%, the region can be categorized as 'high' water stress region.

North Eastern Region

North eastern region of the country comprises of 7 states of Assam, Arunachal Pradesh, Manipur, Meghalaya, Mizoram, Tripura and Nagaland. The region comprising of these states spreads over an area of 2,55,037 km², equivalent to 7.7% of the country's surface area. However, we selected Assam as the representative state from the region, for water availability and demand modeling studies. Assam with an area of 78,438 km² occupies 31% of the region and its total population represents 68% of the population of north eastern region. Geographically, two-thirds of the north eastern region is hilly terrain and only few parts of Brahmaputra-Barak river system representing the plain area.



Figure 2.29: Location map of Assam, North-Eastern region

Hydrological characteristics

North eastern region of the country is drained by Brahmaputra-Barak river system. Average water resources potential of the system is 585 BCM which is highest among all the river basins of the country. However, utilizable potential of the basin is very less and limited to only 5% of the total water available.

Rainfall distribution

Area weighted annual average rainfall in the North eastern region is about 2630 mm, which is much higher than the national annual average of 1187 mm. Within the region, all the states receive annual rainfall of more than 2000 mm with least in Nagaland, Mizoram, Manipur and Tripura. Assam receives an annual rainfall of 2625 mm, but Arunachal Pradesh is credited with maximum rainfall of the region with an annual average of 2900 mm.

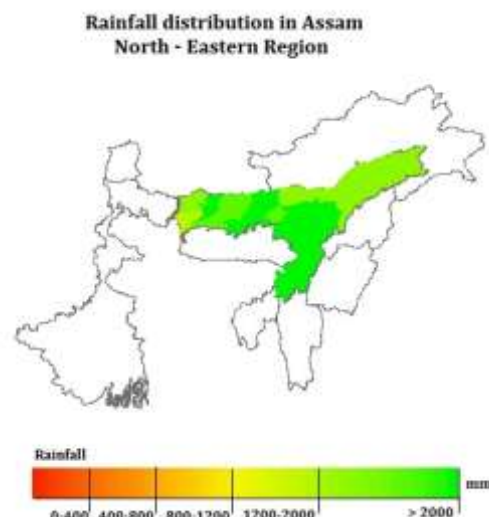

Figure 2.30: Rainfall distribution in Assam, North-Eastern region

Water availability in the region

North eastern region has 5.7% of total utilizable surface water resources of the country and 8.7% of net annual groundwater availability of the country. As such contribution of groundwater to the total water availability in the region is higher than the contribution of surface water, but the total availability of groundwater is limited only to a few states of the region. Assam has 74% of the net annual ground water availability followed by Arunachal Pradesh and Tripura. Together these three states have 92.5% of ground water available in the north eastern region. Assam also enjoys the maximum utilizable surface water potential among all the states of the region, which is 29% of the total availability. Per capita water

availability is above 1600 m³ in the region which is higher than the national average. Among the states, per capita water availability in Assam is 1200 m³.

Water demand in the region

1.1.1.2 Agricultural Water Demand

Net crop area in Assam is close to 2.78 mHa, almost 90% of which is under paddy cultivation. Irrigation intensity is very low and rainfed cultivation is dominant in the region. As such irrigation water requirement in Assam is only 11% of the total crop water requirement in the state. Also, water requirement for kharif season is higher than in rabi season.

1.1.1.3 Domestic Water Demand

Total human population of the North eastern region is 45.49 million with only 18.5% people living in urban areas, and livestock population is close to 24.8 million. Total water demand for human and livestock consumption in the region is less than 1 BCM. In Assam, rural water demand is higher than the urban water demand and is close to 60% of the total demand in north eastern region.

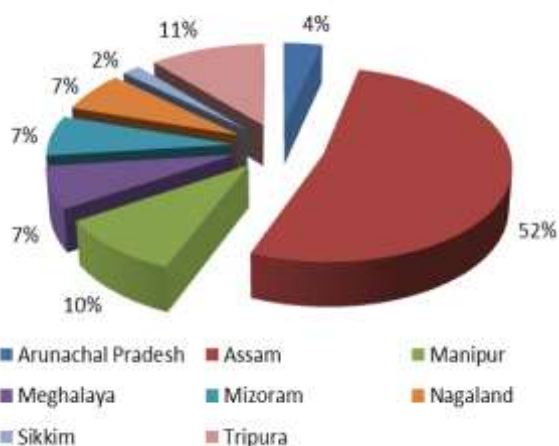

Figure 2.31A: Urban water demand in the North eastern region

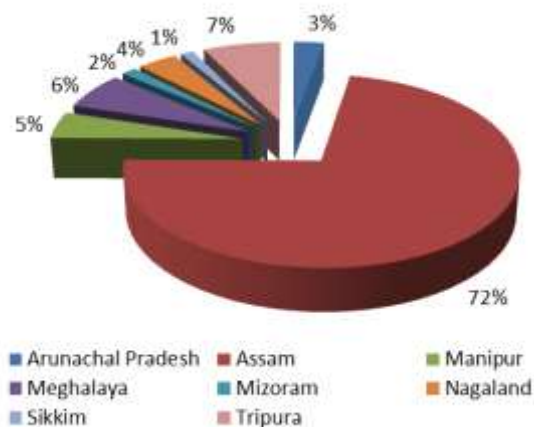

Figure 2.31B: Rural Water Demand in the North eastern region

1.1.1.4 Industrial Water Demand

North eastern region is among the least industrialized regions of the country. A few pulp and paper industries exist in the region which only consumes some notable amount of water. Water consumption from other industries is very negligible.

Water for energy production in the region

Coal based electricity production in the north-eastern region is limited to less than 1% of country's production. However, the region produces some sizeable amount of gas based electricity equivalent to 7% of country's capacity. Hence, water consumption for electricity production in north eastern region is just 0.07 BCM. But Assam and Nagaland in the region have almost 25% of on-shore oil exploration capacity. Oil refining capacity of 7 million

metric tonnes per annum is also installed in Assam. Water consumption for oil exploration and refining in the region is higher than the water consumption for electricity generation and is equivalent to 57% of total water for energy in north-eastern region.

Water stress in the region

Different sectoral water demands for the western region can be distributed as

Table 2.6: Sectoral Water Demand in North-Eastern Region

	Sectoral Water Demand	% Share in total
1	Agricultural	49.3
2	Domestic	41.5
3	Industrial	3.5
4	Energy Production	5.7

On an annual basis, total water demand for the region is only 2% of its total water availability. 54% of total water availability is contributed by surface water and remaining by the ground water resources, primarily located in Assam. As proportion of water demand against water available is less than 20%, the region can be categorized as 'low' or no water stress region.

Spatial and Temporal variation in water availability and stress

Seasonal variation in water availability and stress

India receives an annual rainfall of 4000 BCM which is very high to fulfill the demand for water in the country. However, only small portion of this rainfall could be put for beneficial use limiting the water availability in the country. Moreover, rainfall in the country is highly variable over time and space. Over 75% of the annual rainfall is received in the four rainy months of June to September only thereby leading to large variations on temporal scale. Indian Meteorological Department divides the year into 4 seasons i.e. Winter (Jan-Feb), Pre-Monsoon (Mar-May), Monsoon (may be referred as South West Monsoon) (Jun-Sep) and Post-Monsoon (Oct-Dec) periods. In general during the monsoon season, Konkan and Goa region and Coastal Karnataka receive highest rainfall while West Rajasthan, Rayalseema and Tamilnadu & Pondicherry sub-divisions receive lowest rainfall. Annually, the District of East Khasi Hills in Meghalaya receives highest rainfall whereas the District Ladakh (Leh) in Jammu & Kashmir receive lowest rainfall in the country.

For the purpose of distribution of water availability in the country, we divided the year into two seasons i.e., peak season and lean period, based on the months receiving more than or less than the annual average rainfall. In general, peak season for most of the states is limited to 4 months of a year i.e., June to September. But in some states like West Bengal and Odisha, peak season extends for 5 months and in some states like Kerala, it extends for 6 months from May to October. However in Punjab, peak season extends only for 3 months of a year i.e., July – September. Apart from duration of peak period, timing of peak season also varies in some states of the country. Peak season in Tamil Nadu and Puducherry starts from August and extends upto December. In Jammu and Kashmir, peak season is February to April due to influence of western disturbances, and then from July to August.

In central and western regions, more than 88% of annual rainfall is concentrated within peak season and only 12% available for remaining 8 months. In southern region, all state except Tamil Nadu receives more than 85% of their annual rainfall during peak season. Tamil Nadu receives atleast 30% of its annual rainfall available for 7 months of its lean period. Northern and eastern regions receive close to 85% of their annual rainfall during peak season. Annual rainfall is well distributed in some states of northern India like Himachal Pradesh and Jammu & Kashmir which receive close to 55% of their annual rainfall only, during peak season. Peak season rainfall in north-eastern region is close to 80%.

Table 3.1: Monthly distribution of Rainfall in different Regions

	Sub-division	Jan	Feb	Mar	Apr	May	Jun	Jul	Aug	Sep	Oct	Nov	Dec
NE	Arunachal Pradesh												
NE	Assam and Meghalaya												
NE	Nagaland, Manipur, Mizoram, and Tripura												
E	Gangetic West Bengal												
E	Orissa												
E	Jharkhand												
E	Bihar Plains												
N	Uttar Pradesh												
N	Uttarakhand												
N	Haryana												
N	Punjab												
N	Himachal Pradesh												
N	Jammu & Kashmir												
N	Rajasthan												
W	Madhya Pradesh												
W	Gujarat Region												
W	Maharashtra												
W	Chattisgarh												
S	Andhra Pradesh												
S	Karnataka												
S	Kerala												
S	Tamil Nadu												

1.1.1 Seasonal Distribution of Surface Water Availability

In response to the seasonal distribution of rainfall, surface water availability also varies. Nationally, 85% of total surface water is available only during the peak season of rainfall and remaining for the major parts of the year i.e., almost 8 months of lean period.

Regionally, western and central region are most deficient during the lean period with only 10% of annual surface water available for the period. Northern has maximum lean period surface water availability, while Haryana from northern region and Gujarat from western region are most deficient among the states. Winter precipitation in other states of northern region and eastern region supports the lean period water availability, and ranks them highest in comparison to other regions.

However, uniform temporal distribution of ground water supports the total water availability in different regions. Due to its high ground water potential, northern region has highest water availability during lean period of 8 months, equivalent to about 42% of its annual availability.

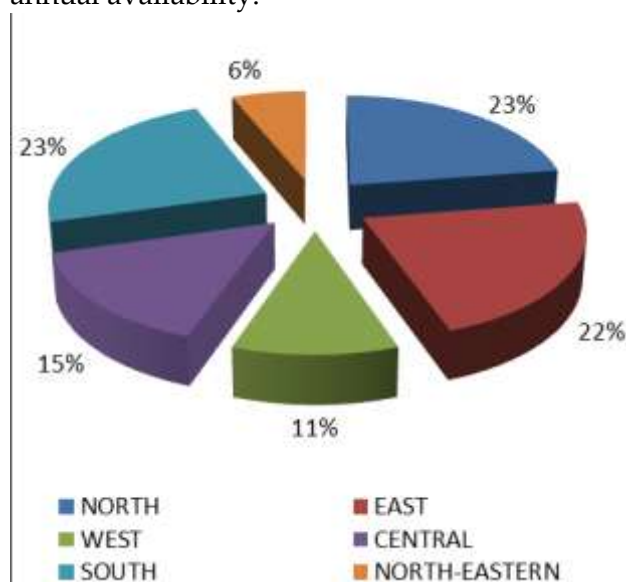

Figure 3.1: Lean period surface water distribution

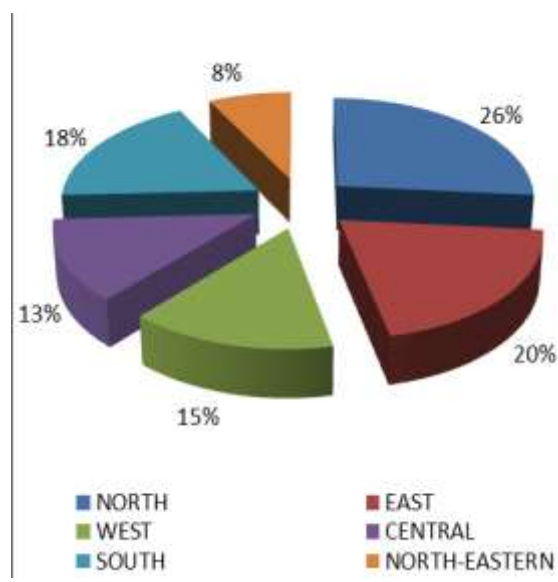

Figure 3.2: Lean period total water distribution

Seasonal Distribution of Sectoral Water Demand

Agricultural Water Demand

In India, rabi season crops except in Tamil Nadu are considered as lean period crops. In Tamil Nadu, kharif season crops are lean period crops. Paddy and wheat are the two distinct kharif and rabi crops being grown in the country respectively. Every region grows either/ both of them. Area under paddy and wheat cultivation is distributed as 60:40, in the country with eastern region having maximum area under paddy cultivation and northern region under wheat cultivation. However, with reference to irrigated cultivation, northern region has maximum area under irrigation of both paddy and wheat.

Accordingly, agricultural water requirement for both kharif and rabi season is highest in northern region as compared to other regions of the country, and the same is distributed as 58% and 42% respectively. Southern region is another important cultivator of irrigated paddy and so its kharif water requirement for agriculture is higher than other regions,

except northern. In western region, wheat cultivation is almost double its paddy cultivation, and so lean period water requirement in this region is 2nd highest after northern region. At the national level, agricultural water requirement is distributed between peak and lean period as 56% and 44% respectively.

Domestic Water Requirement

Domestic water demand is almost uniformly distributed throughout the country, as no reliable estimates of seasonal variation were available. However, as per general understanding it may be considered that domestic water requirement will be higher during the summer season of lean period and lesser during the peak monsoon period, thereby increasing the stress on available water resources. Hence, domestic water requirement for 8 and 4 months of lean and peak seasons respectively can be safely distributed as 70:30 percent of the annual requirement. But still, domestic water requirement follows the annual pattern of distribution, itself.

Industrial Water Requirement

Production system of water guzzling industries like textile, pulp and paper, cement, fertilizer and iron and steel, is not governed by seasonality and so industrial water requirement is uniformly distributed over lean and peak periods. As such industrial water requirement follows the annual pattern of distribution.

Water for Energy production

Similar to domestic water requirement, water for energy production is also distributed uniformly throughout the year. Data from Central Electricity Authority indicates a variation of 1-5% in amount of electricity generation from power plants during the year, with minimum production during July and August months of peak season. Thus, electricity production is more during the lean period than the peak season, and so the water consumption for electricity production can be distributed as 70:30 percent of annual requirement during the 8 and 4 months of lean and peak seasons, respectively.

Total water requirement for the production of energy in the western region is almost equivalent to its industrial water requirement. 87.5% of water for energy in the region is consumed for production of electricity and remaining for the exploration and refining of petroleum. With reference to water consumption for energy production, major states of the region can be ranked as Maharashtra > Gujarat > Rajasthan, however, the top two states are responsible for consumption of almost 84% of total water.

Inter-regional assessment of variability in water availability and demand

Water availability and its demand are highly variable both spatially as well as temporally in the country. All the studied regions in our study also show high variability. While previous section covered temporal variability, this section covers the spatial variability in water availability and demand across the regions. Central Electricity Authority classifies the country into five regions namely – Northern, Western, Southern, Eastern and North-Eastern. Considering the water flow pattern, rainfall scenarios and general understanding, we created a separate Central region including Madhya Pradesh and Chattisgarh and included Rajasthan as part of western region within our study.

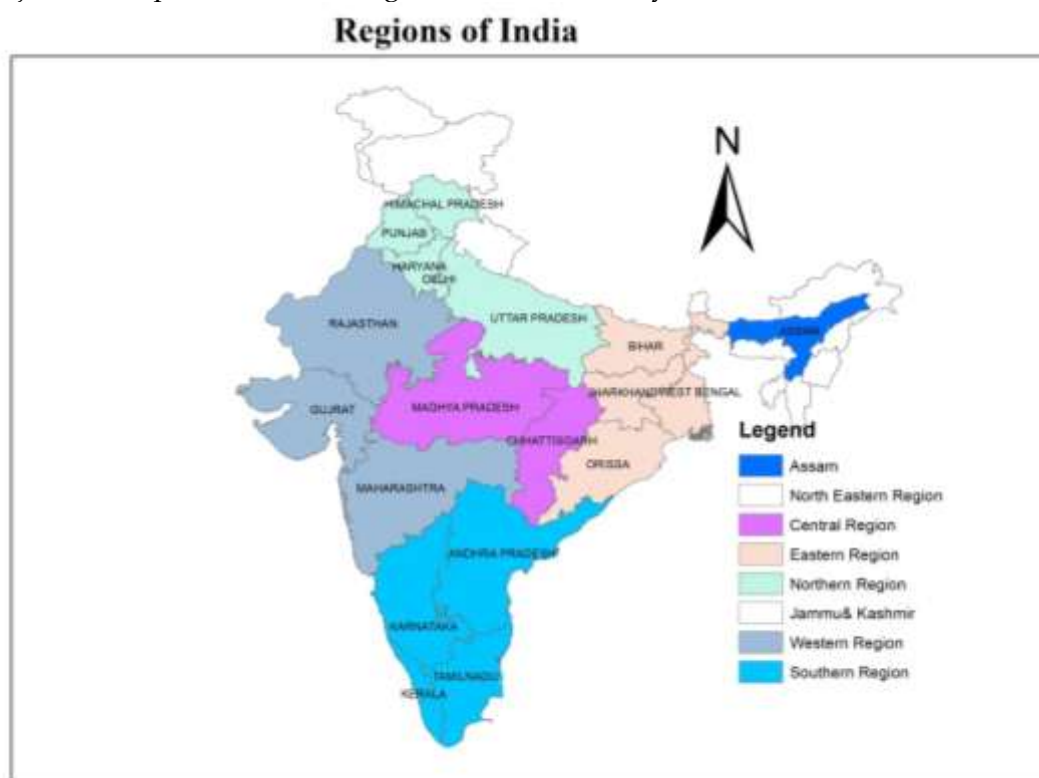

Figure 3.3: Grouping of different states into regions

Hydrological Characteristics

River basin is considered as the basic hydrological unit for planning and development of water resources. Central Water Commission has divided the country into 22 major river basins with catchment area of 20000 km² and above. The major river basin is the Ganga-Brahmaputra-Meghna, which is the largest with catchment area of about 11.0 lakh km² (more than 1/3rd of the catchment area of the country). The other major river basins with catchment area more than 1.0 lakh km² are Indus, Mahanadi, Godavari and Krishna.

1.1.1.1 Inter-regional variation Rainfall Distribution

Rainfall is the primary source of water and is of great importance for India's Economy, especially for agriculture sector. It is highly variable over space and time, leads to flood and drought every year on one or the other part of the country.

Area weighted annual average rainfall in the country is 1187 mm but it has great spatial variations. The areas on the Western Ghats and the Sub-Himalayan areas in North East and Meghalaya Hills receive heavy rainfall of over 2500 mm annually, whereas the Areas of Northern parts of Kashmir and Western Rajasthan receive rainfall less than 400 mm. A significant feature of India's spatial rainfall distribution is that, it decreases westwards in the north but decreases eastwards in the Peninsular India, except in coastal region.

Among the six studied regions, North-East region receives maximum rainfall and Western region receives minimum rainfall. Average annual rainfall in North-East region is more than double the national annual average while in Western region, it is almost half of the national average. Average annual rainfall in Eastern region is also above than national average but other regions i.e., Northern, Central and Southern experience rainfall that is almost equivalent to national average.

Thus, 26% of the country receives below average rainfall, 21% above average and 53% receives rainfall equivalent to national average.

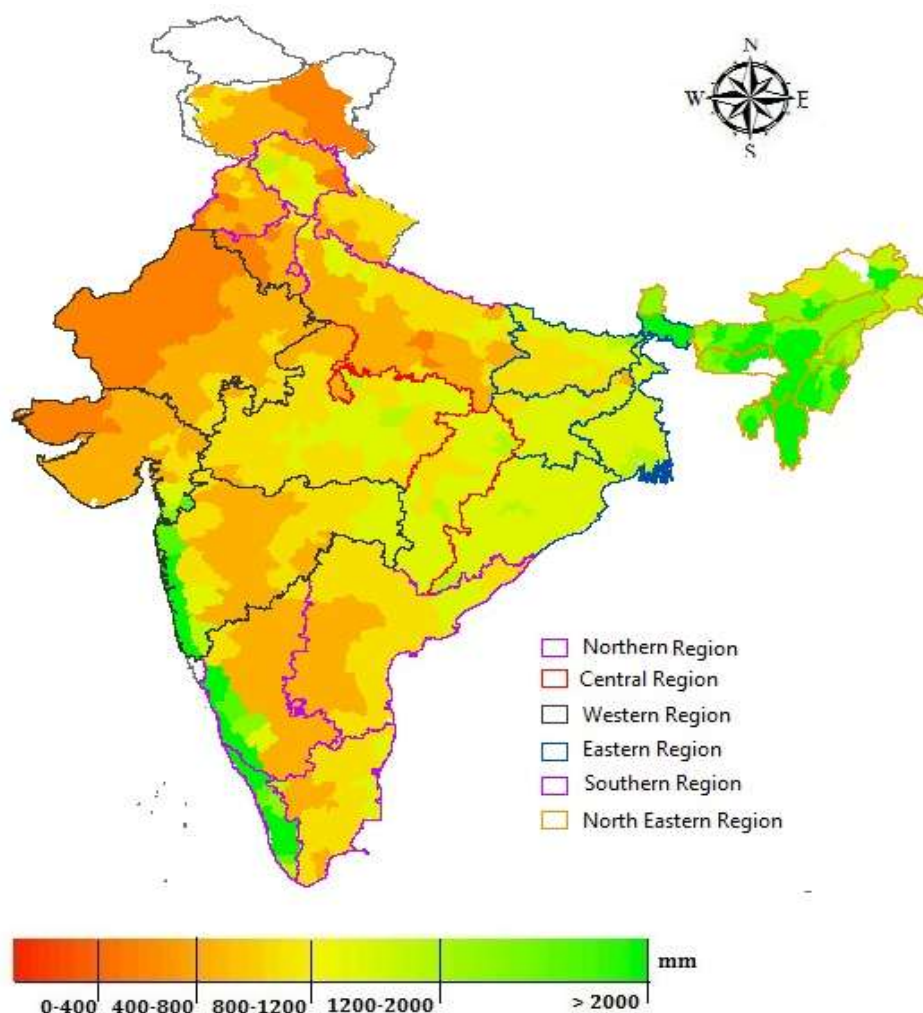

Figure 3.4: Rainfall Distribution in India

Inter-regional variation in Water Availability

The average annual precipitation in volumetric terms is 4000 BCM. The average annual surface flow out of this is 1869 BCM, the rest being lost in infiltration and evaporation. This is the *average water resources potential* in India. But the amount of water that can be actually put to beneficial use is much less due to severe limitations posed by physiography, topography, inter-state issues and the present state of technology to harness water resources economically. According to *Central Water Commission*, utilizable surface water resources in the country are about 690 BCM (about 36% of the total water). This is the amount of water that can be purpose fully used, without any wastage to the sea, if water storage and conveyance structures like dams, barrages, canals, etc. are suitably built at requisite sites. Additionally, the potential of dynamic or *rechargeable* ground water resources of our country has been estimated by the *Central Ground Water Board* to be about 432 cubic km.

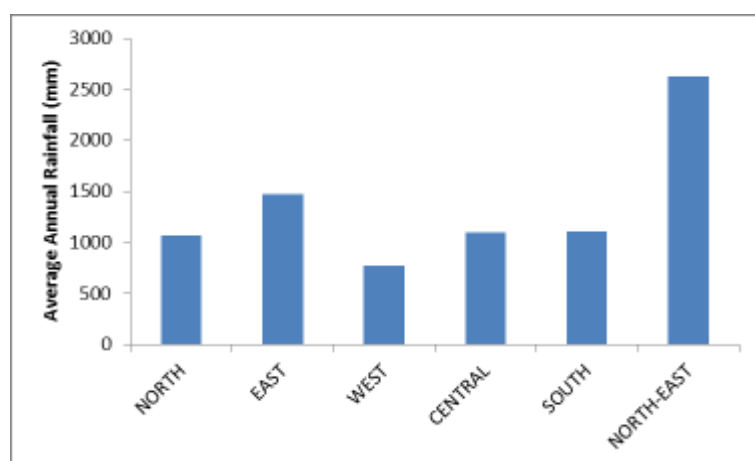

Figure 3.5: Variation in average annual rainfall in different regions

Table 3.2: Water resources of India

Average annual precipitation volume	4000 BCM
Natural runoff (Surface water and ground water)	1869 BCM
Estimated utilizable surface water potential	690 BCM
Ground water resources	432 BCM

Average water resources of the country are distributed among different river basins differently, depending on the differences in the rainfall in river catchment and their runoff patterns. Ganga-Brahmaputra-Meghna river basin is largest both in respect of their catchment area as well as average water resources potential, accounting for more than 50% of the total water resources in the country. However, proportion of utilizable surface water resources to average water resources potential is very high in smaller basins and is least in

Brahmaputra basin. Some of the river basins with more than 50% of their water resources potential as utilizable are Pennar, Godavari, Krishna and Cauvery. River basins south of Indo-Gangetic plains ensure 54% of total utilizable surface water resources in the country. Accordingly, southern and central regions of the country have highest utilizable surface water resources, amounting to 41%. Due to its topography, north-eastern region while receiving maximum rainfall has least utilizable surface water resources. Similarly, northern region lying entirely within the Indo-Gangetic plains ranks second last after north-eastern region with reference to utilizable surface water resources.

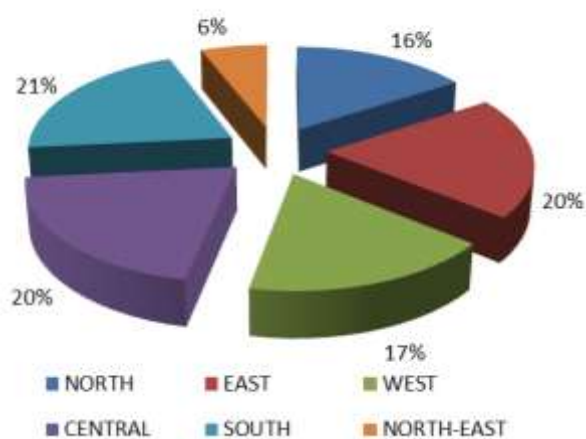

Figure 3.6 A: Region-wise distribution of Potentially Utilizable Surface Water Resources

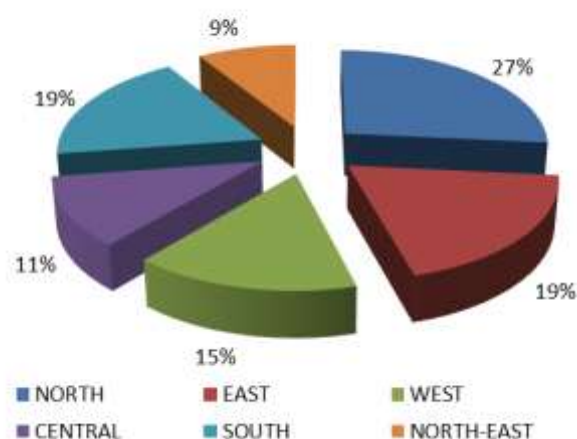

Figure 3.6 B: Region-wise distribution of Potentially Utilizable Ground Water Resources

However, net annual ground water availability is highest in northern region and least in north-eastern region. States in eastern and southern region also has high ground water availability though their distribution within the region is not uniform. West and central region may be considered as having moderate ground water availability.

Inspite of differences in their area and annual average rainfall, combined potential of surface and ground water resources is same for northern, eastern and southern regions of the country.

Inter-regional variation in Water Requirement

1.1.1.2 Agricultural Water Requirement

Net area under crop cultivation is maximum in western region and least in eastern region after north-eastern region. According to net area under agriculture, different regions can be categorized as Western>Southern>Northern>Central>Eastern>North-Eastern. However, proportion of net area irrigated to net area cultivated is maximum in northern region, and accordingly different regions could be categorized on the basis of net area irrigated as Northern>Western>Southern>Eastern>Central>North-Eastern.

Among area under cultivation for different crops, paddy cultivation is maximum in eastern region and wheat cultivation is maximum in northern region. Pulses and oil crops occupy maximum cultivated area in western region and least in north-eastern region. Among other regions, southern and central regions have significant area under pulses and oil crops cultivation.

However, a different pattern is observed with reference to net area irrigated under different crops. Irrigated area under paddy and wheat cultivation is maximum in northern region. Among cash crops, irrigated sugarcane area is maximum in northern region, but area under cotton is maximum in western region.

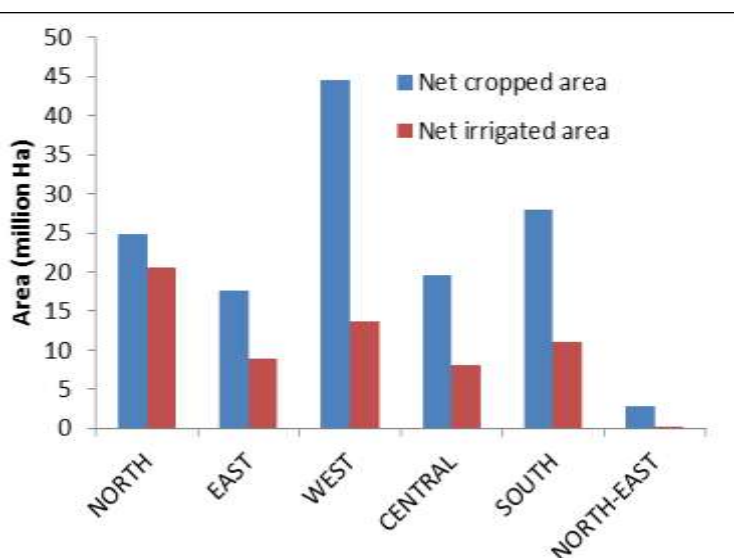

Figure 3.7: Net crop area and Net irrigated area across different regions

Among the five biggest regions of the country, agricultural water requirement is highest in Northern region and least in central region. Irrigation water requirement in northern region is almost 3.5 times that of central region. Among the other three regions, western region has a higher water requirement for its crop cultivation, while eastern and southern region have almost equivalent requirement.

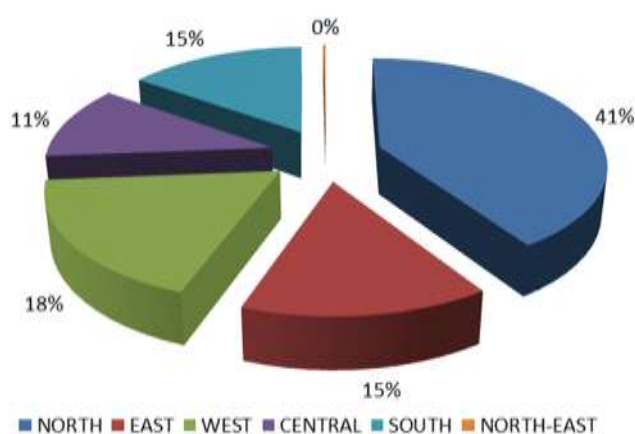

Figure 3.8: Irrigation water requirement across different regions

Similarly, eastern and northern regions of the country are most rural as compared to other regions.

1.1.1.3 Domestic Water Requirement

Northern region with a about 300 million people is most highly populated region of the country, closely followed by the eastern region. Other regions like western, southern and central have far lesser population as compared to northern and eastern regions, which account for almost half of country's population. Southern region of the country is most highly urbanized followed by western and northern regions.

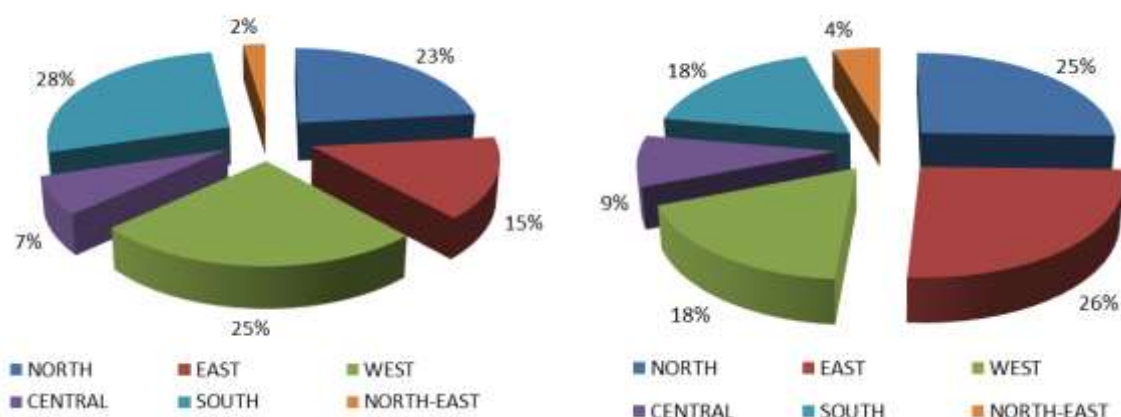

Figure 3.9A: Region wise urban population of India

Figure 3.9B: Region wise rural population of India

Water demand for rural and urban areas follows the trajectory similar to their regional population. Southern region with highest urban population has highest urban water demand and eastern region with highest rural population has highest rural water demand. With reference to total domestic water demand, even after having almost half of the population than the region with highest population, southern region has highest water demand which is almost equivalent to the demand from northern region. Except for eastern region, urban water demand is more than the rural water demand in all the regions. In western and southern regions, urban demand is almost double their rural water demand.

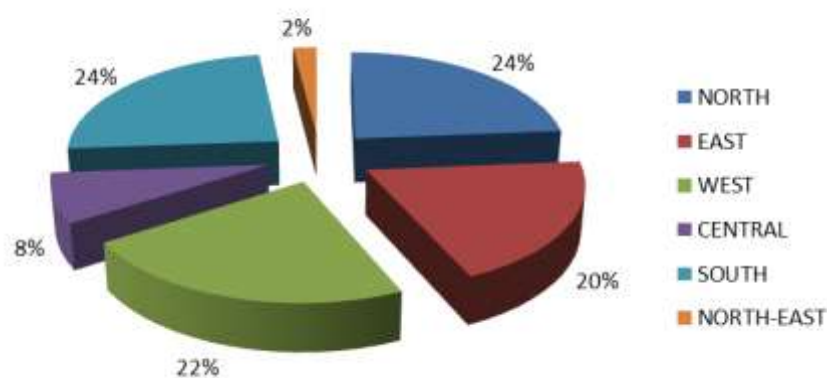

Figure 3.10: Region-wise Domestic water requirement in the country

1.1.1.4 Industrial Water Requirement

Among the manufacturing sector, textile, pulp and paper, cement, fertilizer and iron and steel industry are the biggest consumer of water. These industries are distributed across different regions, non-uniformly and so industrial water demand varies across the regions. Textile and fertilizer and cement industries are present in all the regions, while iron and steel industries is concentrated more densely in some regions. Among different types of industries, iron and steel industry is the biggest water guzzler accounting for 72% of total industrial water consumption in the country. Eastern, western and southern regions account

for maximum water consumption for iron and steel industry. Eastern region is also responsible for maximum industrial water consumption i.e., 37% of total, followed by southern (26%) and western (22%) regions. Southern region with maximum textile units has maximum consumption of water for the industry.

Inter-regional variation in Water for Energy

Thermal electricity production dominates the energy scenarios of the country. As on December 2016, all India installed capacity of thermal electricity production was 215 GW with a share of 87.7% from coal based power plants. Western region is the top electricity producer in the country, producing almost one third of total electricity in the country. Western region is also responsible for 73% onshore exploration of petroleum in the country and has 47.3% of country's oil refining capacity. The region is also credited with production of almost 25% of country's bio-fuel based energy. Hence, water consumption for energy production is highest in western region, followed by southern and eastern regions. Across the country, 76% of total water required for energy production is used in thermal electricity production. Water consumption for oil and gas exploration as well as refining is only 6.4% of the total water for energy.

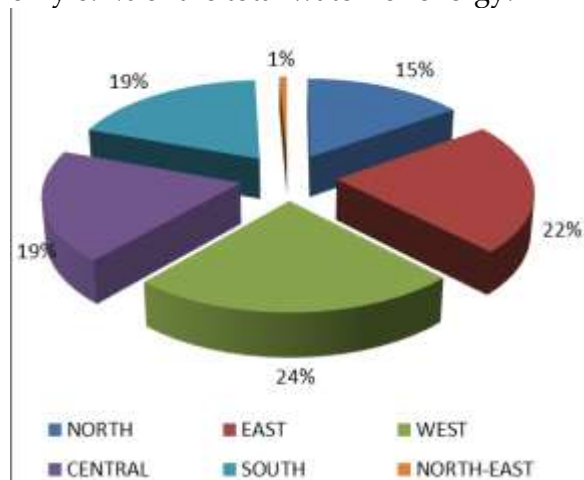

Figure 3.11A: Water for thermal electricity production

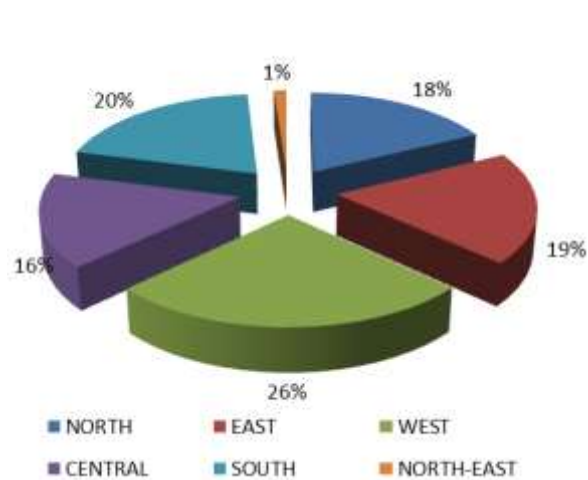

Figure 3.11B: Water for energy production

With reference to water consumption for energy production, different regions can be ranked as Western>Southern>Eastern> Northern> Central>>North-Eastern.

Inter-regional variation in Water Stress

Water stress could be defined as requirement for water as percentage of total water available. It signifies the competition for available water from water required by different sectors. As percentage between the minimum total water requirement and total water available, we classify water stress into 5 categories: Low, Medium, High, Very High and Deficit.

Table 3.3: Baseline water stress categories and stress percentage

	Stress Category	Stress Percentage
1	Low Water Stress	<25%
2	Medium Water Stress	25% - 50%
3	High Water Stress	50% - 75%
4	Very High Water Stress	75% - 100%
5	Deficit	>100%

With reference to minimum water requirement from different sectors of the economy viz., agriculture, domestic, industrial and energy, sufficient water is available in the country both nationally as well as within different regions and none of them have deficit. Sectoral water requirement in different regions as well as their water stress can be distributed as

Table 3.4: Regional Water Stress Categorization

		NORTH	EAST	WEST	CENTRAL	SOUTH	NORTH-EAST	NATIONAL
<i>Sectoral Water Requirement (as % of total regional)</i>								
1	Agricultural	93.9	82.5	85.4	90.3	82.3	49.3	88.1
2	Domestic	4.8	9.7	9.3	5.5	11.7	41.5	7.7
3	Industrial	0.5	5.6	2.8	1.5	3.8	3.5	2.4
4	Energy Production	0.8	2.2	2.5	2.7	2.2	5.7	1.8
<i>Regional water stress categorization</i>								
5	Annual Baseline water stress	70.1	28.9	41.2	23.2	29.3	4.8	37.1
6	Stress Category	High	Medium	Medium	Low	Medium	Low	Medium
7	Peak Season baseline water stress	68.5	23.1	28.1	1.2	27.5	2.2	28.4
8	Stress Category	High	Medium	Medium	Low	Medium	Low	Medium
9	Lean period baseline water stress	72.0	40.7	74.1	67	32.6	2.9	52.9

10	Stress Category	High	Medium	High	High	Medium	Low	High
----	-----------------	------	--------	------	------	--------	-----	------

Throughout the country, agricultural water requirement is much higher as compared to water requirement from other sectors. Agriculture sector accounts for 88.1% of total water consumption in the country. Domestic sector is the 2nd largest consumer, amounting for 7.7% of total water consumption in the country. Water requirement for energy production is less than 2% of total water requirements. Individually in each region also, agricultural water requirement is higher than other sector, though their proportion varies in different regions. Agricultural water requirement in northern region is highest both in terms of actual quantity of water as well as proportion with requirement from other sectors. Lower proportion of agricultural water requirement indicates the prominence of water requirement from other sectors in the region, and is indicative of higher competitive stress between agriculture and other sectors for the available water.

1.1.1.5 Water Stress in Annual Time scale

On an annual time scale, proportion of water requirement to water availability is between 25-50%, and so the country can be categorized as being under medium stress throughout the year. However, different regions have different ranking on the water stress scale. Northern region is at the highest stress with its minimum water requirement being 70% of the annual water availability. Western, eastern and southern regions are in the category of medium stress, with western region being at the highest stress among the three. However, central and north-eastern regions are at low stress, with plenty of excess water available for additional uses.

1.1.1.6 Water stress in Seasonal Time scale

During the peak season of rainfall months, water stress reduces throughout the country. Ratio of water requirement to water availability also reduces than the annual ratio. However, northern region still remains under high stress though ration improves 4% points. This is mainly on account of high intensity of irrigated agriculture being practiced in the region.

During the 8 months of lean period, when only limited rainfall is available in the country, country is under high category of stress. Besides northern region, western and central regions also come under high stress, and show a very significant change from their annual stress values. This is mainly due to irrigated wheat cultivation dominating the agricultural scenario in the region. There is very high fluctuation in water stress in the central region as compared to its stress level during the peak season. North-eastern region remains at very low level of water stress during the lean period also.

Assessment of Water Stress for Future Scenarios

Projections under Business As Usual scenarios

Increasing population and rapid economic growth will be leading to increase in water demand from different sectors. Business As Usual scenarios assume that the natural water availability across the river basins and so states in the country will remain constant under the given technological regimes. However, demand for water will be rising continuously. Increasing population and food requirement for the people will drive both the agricultural as well as residential water demand in the country. Simultaneously, increasing urbanization and extension of irrigation facilities in agricultural cropped area will exert further pressure on continuing demand for water. As a result, existing water stress on available water resources will be increasing continuously. To quantify the changes in water stress scenarios from the current levels, an assessment of demand in response to continuing growth in different sectors was conducted.

Agricultural Water Requirement under BAU scenarios

Area under irrigation for different crops is the key driver in influencing the agricultural water requirement. Net crop area among 19 major states in the country, covered under this study, was 138 million Ha in 2009-10, out of which a total of 62.5 million Ha was covered under irrigation facilities. Thus, irrigation intensity in the country is close to 45%. Northern region has highest irrigation intensity with all its states except Uttarakhand, having close to 80% of their crop area covered under irrigation. Among the crops, sugarcane and wheat are the most irrigated crops throughout the country. The decadal growth rates of net irrigated areas were very high till 1990-91. After 1990-91, the growth rate fell to around 15 per cent each in the next two decades. Undertakings of large irrigation projects are facing numerous hurdles, including in land acquisition, environmental issues, rehabilitation and resettlement. Management and maintenance of irrigation canal networks and field channels is also proving to be a major institutional challenge. These factors together make the expansion of surface irrigation difficult.

However, wide variation is seen in terms of extension of irrigation facilities. States like Gujarat and Madhya Pradesh show a compounded annual growth rate (CAGR) of close to 4% over the recent decade. In these states, area under wheat cultivation shows maximum increase in irrigation coverage.

Based on the 20 year CAGR for net irrigated area in each state, we projected the increase in irrigated area for future decades with reference to base year of 2010. However, considering that increase in additional area under crop cultivation is negligible for previous decades, we limit the maximum irrigated area over decades to be the net crop area. For the purpose of projecting net irrigation water requirement, below assumptions were made;

Assumptions for Agricultural Growth Rate

- Maximum area under crop cultivation has already been achieved and additional land under agriculture is not possible
- Additional land brought under irrigation is the primary criteria for increase in agricultural water consumption
- Maximum area that could be irrigated under any crop is the maximum net crop area
- Negative growth rate in NIA is possible only if NCA is also decreasing correspondingly

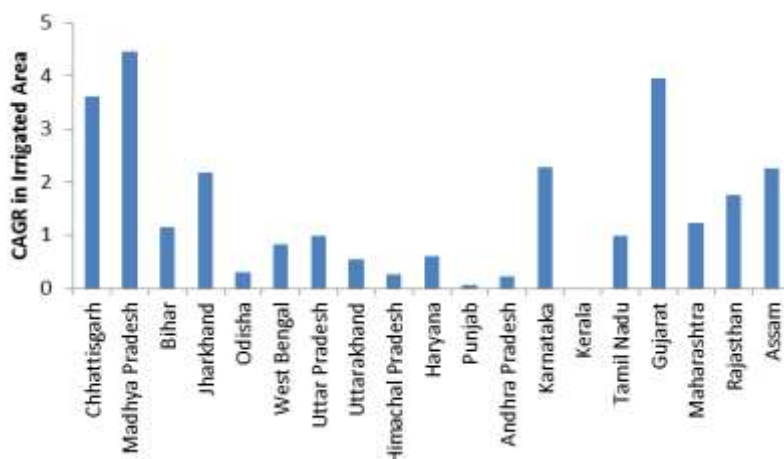

Figure 4.1 : Compounded Annual Growth Rate in net irrigated area for different states

PODIUM Sim model was used again to calculate the future irrigation water requirement based on new net irrigated area for individual crops. The model outputs indicate that over the next two decades from the baseline, there is maximum increase in net irrigated area which becomes almost stagnant subsequently. Maximum increase in agricultural water requirement is likely to be in states like Bihar, Jharkhand, Madhya Pradesh, Gujarat and

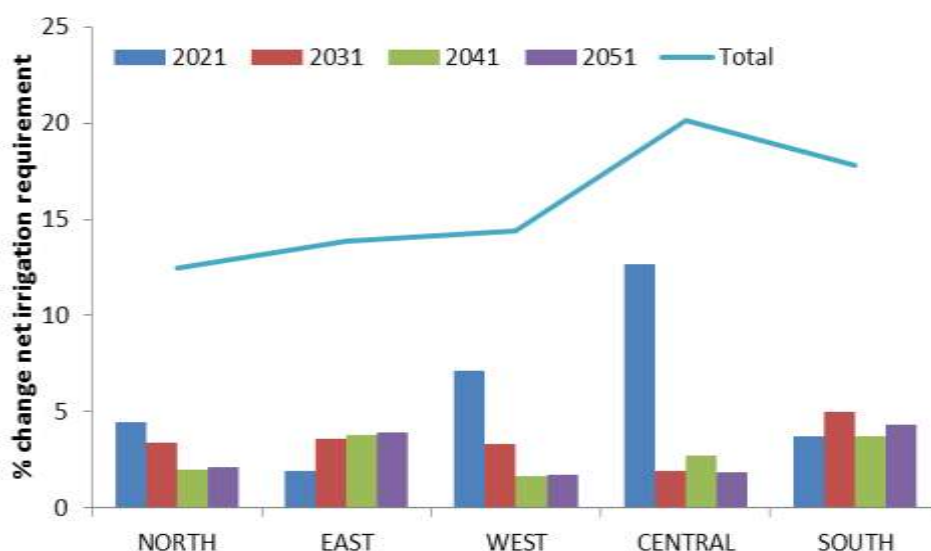

Figure 4.2 : Percentage Decadal Change in Irrigation Water Requirement

Karnataka. States in northern region which already have highest potential crop area covered under irrigation facilities, do not show much increase in their already high agricultural water requirement.

Residential Water Requirement under BAU scenarios

For the purpose of projecting residential/ domestic water requirement, increase in population as well as increase in urbanization was used as the key drivers. Projected values of rural and urban population were taken from Population Foundation of India's (PFI) report "Future Population of India: A long range Demographic View" published in August 2007. In the report, population of India and states is projected till 2101 using Cohort Component Method of population projection, which is the universally accepted method for any study on demographic projections. Moreover, it gives a state-wise rural and urban breakup of population in India. However, these projections made with the Census of India 2001 as the base year, while show a best pattern of growth for most of the states, they do not follow the population as per Census of India 2011. Hence, the data was calibrated using Census 2011 population figures, and projected population was corrected accordingly. These corrected rural and urban population figures were used for projecting the residential water requirement from the current period to future decades upto mid-century.

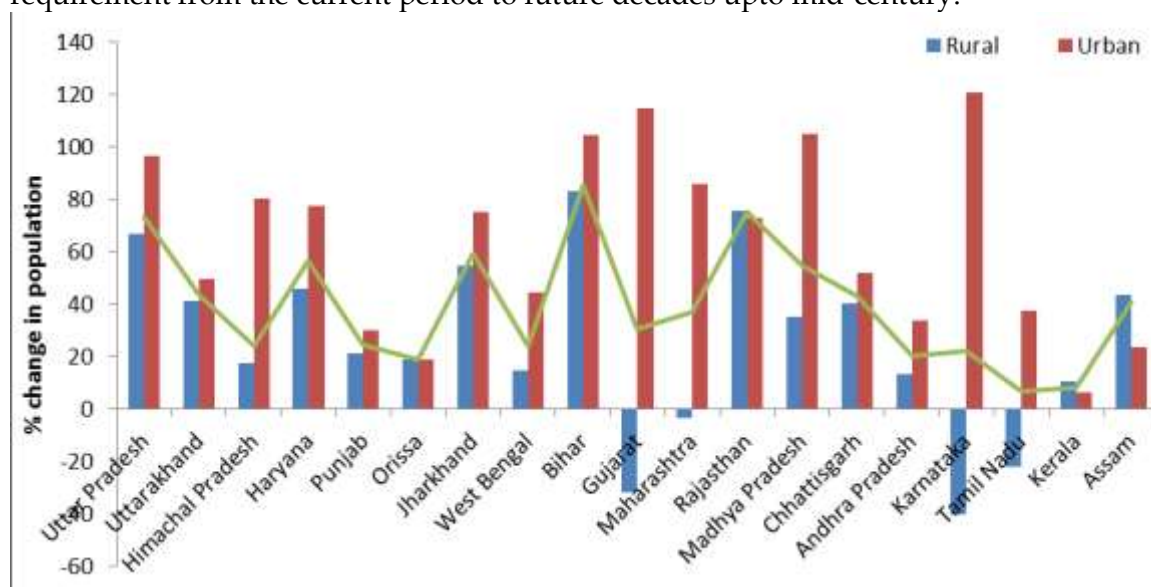

Figure 4.3 : Percentage change in Rural and Urban population in India by 2050

Maximum increase in population is recorded for the states of Uttar Pradesh, Bihar and Rajasthan and least for Kerala and Tamil Nadu. Rural population is declining in industrialised states of the country, i.e., Karnataka, Tamil Nadu, Gujarat and Maharashtra. Maximum increase in rural population is projected for Bihar and Rajasthan. Similarly, maximum increase in urban population is recorded for Karnataka, Gujarat. States like Bihar, Uttar Pradesh and Madhya Pradesh also show a significant increase in state urban population. On a regional basis, maximum increase in population is observed for northern region, followed by eastern and central regions showing almost equivalent growth percentage over 40 years. Significantly, very less population growth is observed for southern region, limited to 15% only.

Correspondingly, pattern of residential water requirement also varies. However, quantum of water varies from region to region due to difference in urbanization patterns. Also, for the

assessment of future water requirement, we assume below changes in Litre Per Capita Per Day (LPCD) requirement norms for rural and urban areas:

Table 4.1: Litre Per Capita Per Day (LPCD) norms for Rural and Urban areas

	Rural	Urban
2011	40	135
2021	50	150
2031	50	165
2041	60	180
2051	70	200

Maximum cumulative increase in residential water requirement is observed for Bihar and least for Kerala. Along with Kerala, below 100 increase in water requirement is noted for Punjab, Orissa, Andhra Pradesh and Tamil Nadu. Other states likely to show a very high increase in cumulative water requirement for mid-century time period are Uttar Pradesh, Rajasthan, Madhya Pradesh, Jharkhand and Haryana.

On a regional scale, decadal as well as cumulative increase in residential water requirement will be highest in northern region, closely followed by central, western and eastern regions. Southern and North-eastern regions show minimum increase among all regions of the country.

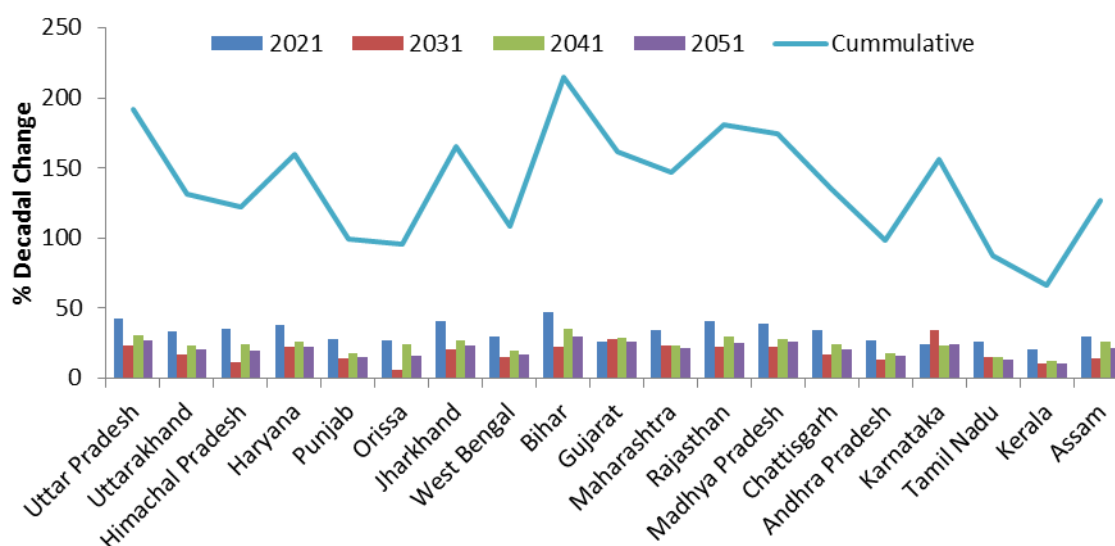

Figure 4.4 : Percentage decadal change in Residential Water Requirement

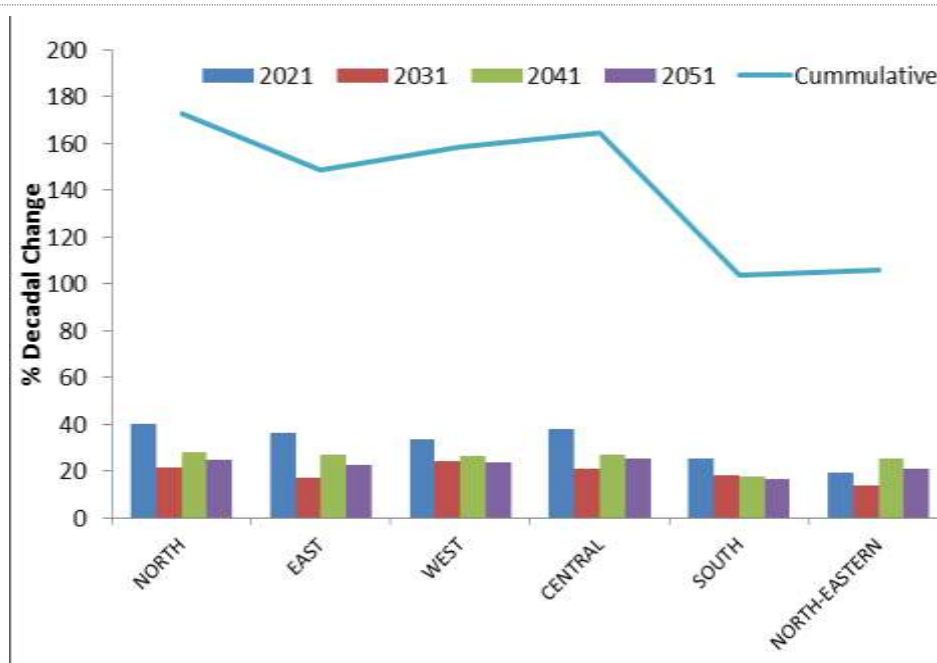

Figure 4.5 : Decadal change in Residential Water Requirement for different regions

Industrial Water Requirement under BAU scenarios

For the purpose of projecting industrial water requirement, increase in growth rate for individual industries was taken from India Energy Security Scenario 2047 (IESS-2047) (Table).

Table 4.2: Base Level CAGR Growth of Industries (Source: IESS-2047)

Industry	2012	2022	2032	2042
Cement	0.088	0.061	0.037	0.019
Fertilizer	0.014	0.006	0.005	0.002
Iron and Steel	0.123	0.091	0.064	0.034
Pulp and Paper	0.122	0.116	0.040	0.033
Textile	0.019	0.028	0.022	0.014

CAGR for different water intensive industries is highest for Iron and Steel and Pulp and Paper industries, for the first decade of study period. However, their growth rate also declines for subsequent indicating near stagnancy during the 4th decade.

Maximum increase in industrial water requirement is projected for the eastern region which is mainly due to increase in iron and steel industry in the region. Western and central regions closely follow the eastern region, however, the increase in these regions is associated with growth in non-iron and steel industry also. Northern region shows minimum increase in industrial water requirement over 40 years time period from the base year.

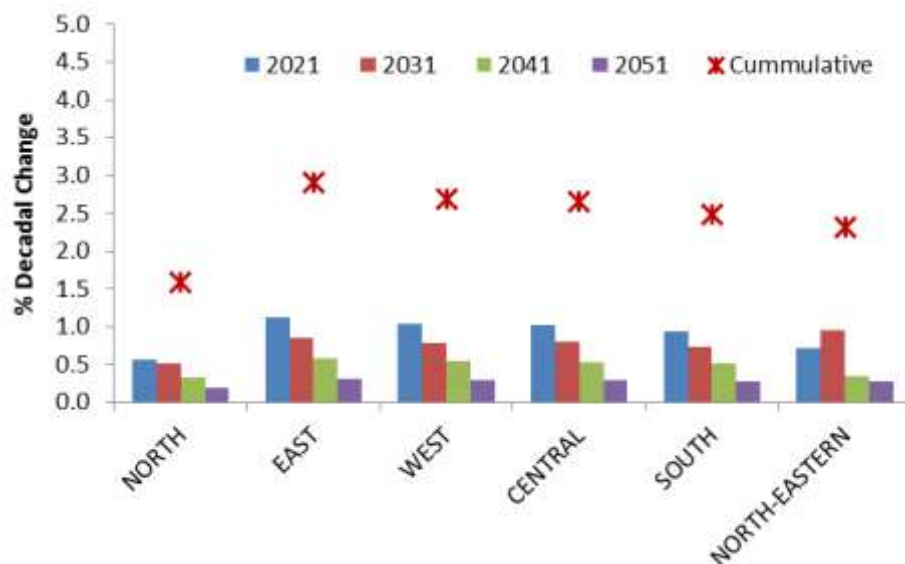

Figure 4.6: Decadal change in Industrial Water Requirement for different regions

Water Requirement for Energy Production under BAU scenarios

National level projections for electricity production in the country indicates that coal and gas based thermal electricity production will continue to dominate the India energy scenarios. IESS 2047 scenarios estimate that installed capacity of coal based electricity production in the country will increase from 125 GW in 2012 to 333 GW in 2047 under L2 scenarios and to 459 GW under L3 scenarios. Under both L2 and L3 scenarios, the rate of increase in installed capacity will be very high upto 2030s but will decline thereafter. However, state level projections of installed capacity are not available. Hence, we calculated the CAGR for the projected installed capacity under IESS-2047 L2 , and applied these rates on the current installed capacity of individual states.

Table 4.3: CAGR for coal based installed capacity

	CAGR
2011-2021	7.18
2021-2031	2.37
2031-2041	0.46
2041-2051	0.12

Similarly, for biofuel based electricity production, decadal CAGR in growth of bio-electricity production from IESS-2047 were used. For other sectors of energy production like coal mining, coal washeries, oil production and oil refining, CAGR for the past production trends was calculated. Combining these growth rates with general understanding about the growth, constraint and import dependencies, state wise decadal growth in various energy sectors was calculated to assess the minimum water requirement for their production activity.

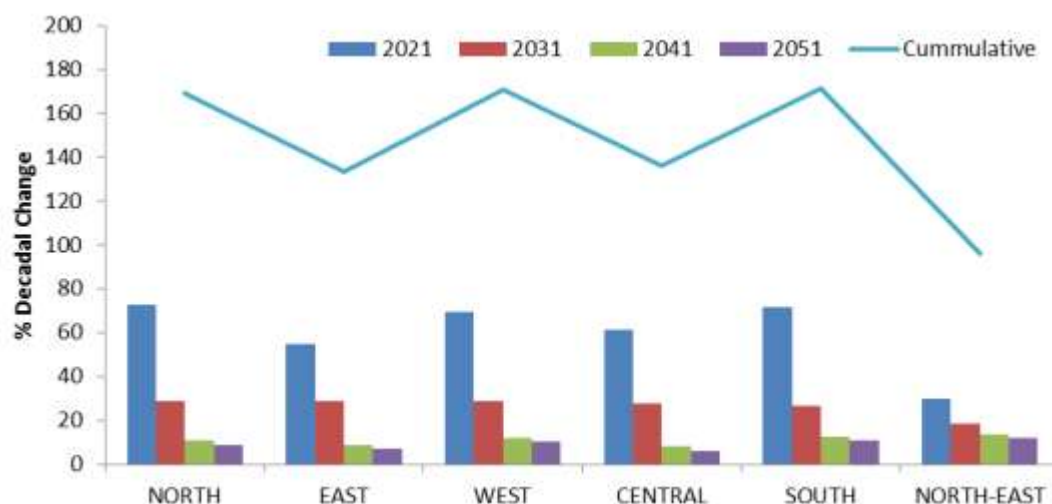

Figure 4.7 : Decadal change in Water Requirement for Energy production in different regions

At the regional level, Northern, western and southern regions show maximum increase in cumulative water consumption by the middle of this century as compared to other regions.

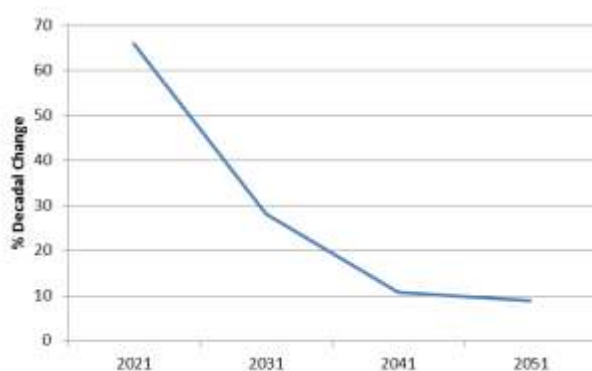

Figure 4.8 : Decadal change in Total Water Requirement for Energy Production in the Country

Variations in Minimum Water Requirement under BAU scenarios

Minimum water requirement remains highest in northern region throughout the projection period, followed by western, southern and eastern regions. Decadal change in demand is highest during the first decade of study period in all the regions except eastern region where it is higher in the last two decades as compared to the first two decades. A significant decline in growth of water requirement is noticed in central and western regions, which is mainly due to maximum area under irrigation being brought under irrigation facility during the first decade itself.

Among the five most populated and most stressed regions of the country, cumulative change in minimum water requirement is almost uniform in eastern, western and central regions, in spite of difference in the change in their sectoral water requirement. Also, northern region while requiring maximum water among all the regions shows minimum increase in its requirement for the future decades.

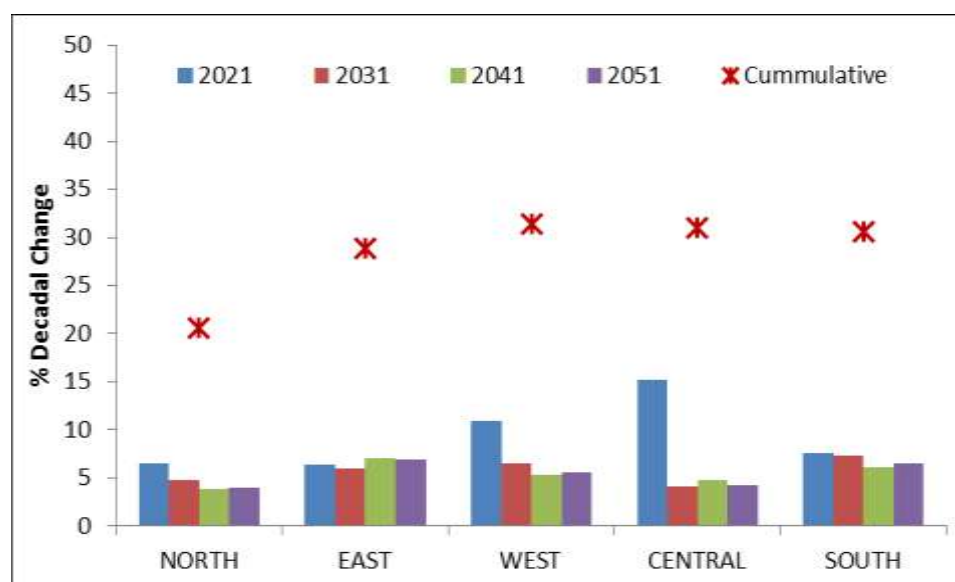

Figure 4.9 : Decadal change in Minimum Water Requirement in different regions

Water Stress Variation under BAU scenarios

In response to the increasing water demand from different sectors, and stagnant water availability scenarios, water stress under BAU scenarios increases over time both at the national level as well as regionally. Maximum change is water stress situation under BAU scenario is observed for Northern and western regions. Northern region remains under high stress condition until 2021, and reaches to the 'very high Stress' level, subsequently. Similarly, current stress level of 'medium stress' in western region while intensify during the first two decades until 2031, but subsequently the region shifts to 'high stress' level. Water stress in north-eastern and eastern regions while intensifies throughout the projection period, it remains within the 'low' and 'medium stress' levels, respectively.

Nationally, country shifts from middle levels of medium stress level to the final levels of medium stress level and is likely to be in high stress levels in post-mid century decades.

Table 4.4: Regional Water Stress under BAU Scenario

	NORTH	EAST	WEST	CENTRAL	SOUTH	NORTH EAST	NATIONAL
2011	70.1	28.9	41.2	23.2	29.3	4.8	37.1
	High	Medium	Medium	Low	Medium	Low	Medium
2021	74.2	30.7	45.7	26.7	31.4	5.8	40.4
	High	Medium	Medium	Medium	Medium	Low	Medium
2031	77.7	32.6	48.7	27.8	33.7	6.8	42.9
	Very High	Medium	Medium	Medium	Medium	Low	Medium
2041	80.8	34.8	51.2	29.1	35.8	8.6	45.3
	Very High	Medium	High	Medium	Medium	Low	Medium
2051	84.0	37.3	54.1	30.3	38.2	10.8	47.9
	Very High	Medium	High	Medium	Medium	Low	Medium

Projections under Specific Government Schemes

To understand the implications of various government schemes on the future water demand and hence, the water stress, we assessed government schemes and tried to quantify their implications on water sector.

Two specific schemes assessed were:

1. Pradhan Mantri Krishi Sinchayee Yojana (PMKSY)
2. Draft New Electricity Policy 2016

Pradhan Mantri Krishi Sinchayee Yojana (PMKSY)

PMKSY has been formulated with the vision of extending the coverage of irrigation '**Har Khet ko pani**' and improving water use efficiency '**More crop per drop**' in a focused manner with end to end solution on source creation, distribution, management, field application and extension activities. PMKSY has been approved for implementation across the country with an outlay of Rs. 50,000 crore in five years. The major objective of PMKSY is to achieve convergence of investments in irrigation at the field level, expand cultivable area under assured irrigation, improve on-farm water use efficiency to reduce wastage of water, enhance the adoption of precision-irrigation and other water saving technologies (**More crop per drop**), enhance recharge of aquifers and introduce sustainable water conservation practices by exploring the feasibility of reusing treated municipal waste water for peri-urban agriculture and attract greater private investment in precision irrigation system. Thus, knowing the fact that agricultural sector claims for maximum amount of water in the country, initiatives envisaged under PMKSY can have a huge impact on water-supply relation.

PMKSY Scenarios: Considering the primary stress of PMKSY to expand the irrigation command area and increase water use efficiency, we develop PMKSY scenarios over BAU scenarios for 2021 and 2031. The scenario assumes achievement of **full irrigation water use efficiency** by 2031. Full irrigation water use efficiency requires an improvement from current levels of 30% for surface water irrigation and 55% for groundwater irrigation water use efficiency, to 50% and 75% respectively. Achievement of efficiency above that may not be within the practical feasibility.

The results indicate that under PMKSY scenarios significant saving is possible in terms of volume of water consumed in agriculture sector, which could be extremely helpful in reducing water stress for other sectors like domestic and industrial.

Under Business as usual scenarios, agricultural water demand is likely to increase by 5.5% and 9% by 2021 and 2031, respectively. This will further add to the already existing stress among different water use sectors, enhancing the water scarcity scenarios. But due to implementation of initiatives under PMKSY, a reduction in water consumption upto 27% could be achieved by 2031. This saving will be almost equivalent to the total water requirement of country's domestic sector.

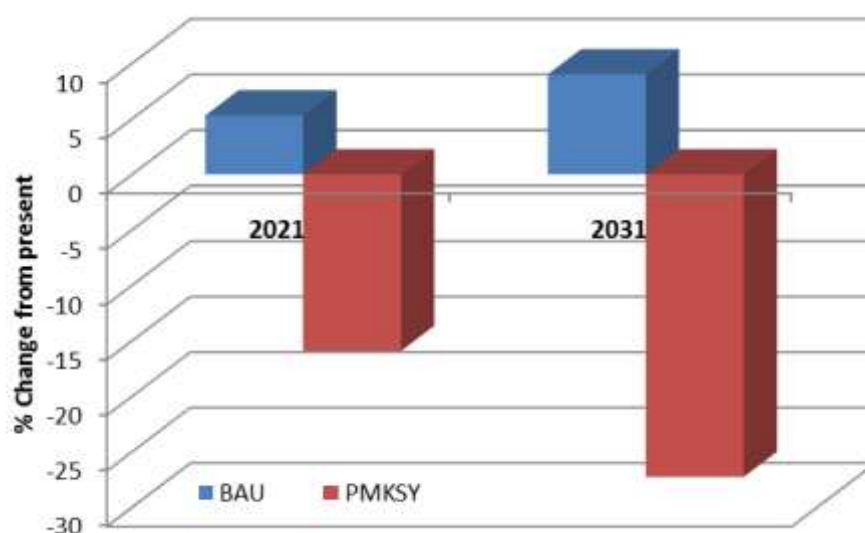

Figure 4.10: Country wide reduction in irrigation water consumption by 2021 and 2031, under PMKSY scenarios

On a regional basis, states in northern, eastern and southern region will be the biggest beneficiary with water saved from agriculture sector being made available for usage in other sectors. For northern region, a reduction of 16% and 28%, for eastern region, a reduction of 19% and 30% and for southern region, upto 17% and 27% reduction in irrigation water consumption by 2021 and 2031 could be achieved, respectively.

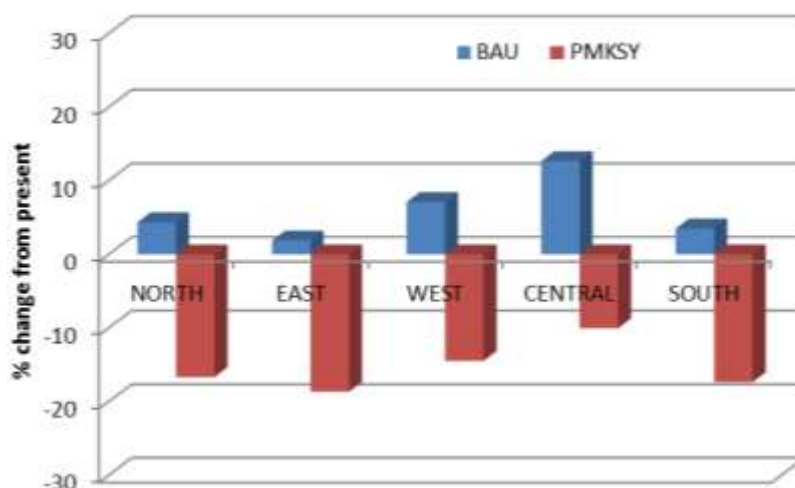

Figure 4.11A: Region-wise reduction in irrigation water consumption by 2021, under PMKSY scenarios

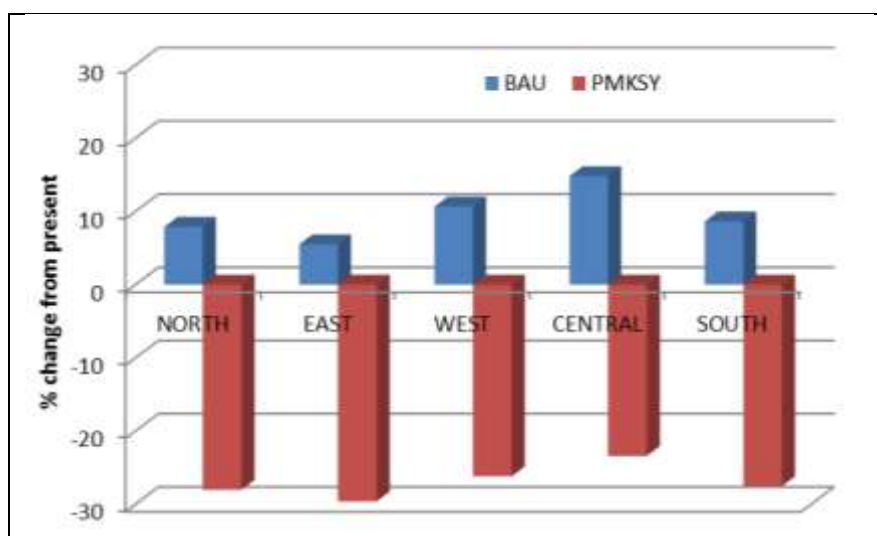

Figure 4.11B: Region-wise reduction in irrigation water consumption by 2031, under PMKSY scenarios

Draft New Electricity Policy 2016 (NEP)

Central Electricity Authority has prepared the National Electricity Plan for the period 2017-22 and a Perspective Plan for the period 2022-27 while reviewing the Status of implementation of the 12th Plan projects. The plan puts ahead a most realistic estimate of the development of power sector in the country for the decadal period from now. Based on the current growth trends and government policies, it provides estimates for new capacity addition in power sector from different sources, like coal, nuclear, solar etc. It is expected that the share of non-fossil based installed capacity (Nuclear + Hydro + Renewable Sources) will increase to 46.8 % by the end of 2021-22 and will further increase to 56.5 % by the end of 2026-27 considering capacity addition of 50,025 MW coal based capacity already under construction and likely to yield benefits during 2017-22.

To estimate the water consumption for the electricity production in the country for the coming decade, we developed NEP scenarios of water consumption. Based on the current and projected water consumption trends in electricity production, we estimate water consumption under NEP scenarios.

Estimation of water demand for coal based electricity production

NEP scenarios estimate the coal based installed capacity of electricity production in the country will increase from 185 GW in March 2016 to 198.5 GW in March 2017 and subsequently new capacity addition will be of 50 GW which will get commissioned by March 2021. Thereafter, no new capacity addition is envisaged upto March 2027. As such, over the next decade, additional water requirement for coal based electricity production shall be 0.9 BCM from the current level of 4-5 BCM.

Estimation of water demand for solar electricity production

NEP shows a more optimistic perspective incorporating recent initiatives by Government of India to promote renewable energy in the country, and estimate it to be about 47 GW by 2022 itself.

We estimate that atleast 0.35 BCM water will be required in 2022 for solar electricity production under NEP scenarios, which will be much higher as compared to other scenarios of solar electricity production.

Estimation of water demand for nuclear electricity production

NEP estimates that with the commissioning of under construction nuclear power plants, their installed capacity in the country will get doubled to about 15 GW by 2027. Accordingly, water consumption for ultimate year of NEP scenarios will be 0.28 BCM respectively.

L2 and L3 scenarios of IESS 2047 indicate a tremendous increase of 130-210% by 2047, in water consumption as compared to the base year of 2012. Similarly, International Energy Organization (IEO) scenarios indicate an increase of about 145% by 2040 from its base year of 2013. However, under both these scenarios, water consumption for installed capacity of electricity production almost doubles over the next decade but NEP scenarios indicate more realistic estimates for the same time period. As per NEP scenarios, water consumption over the next decade increases by only 20% as compared to the present levels.

NEP scenarios which provide an estimate of government's planned targets, project almost 83 GW of additional installed capacity of electricity production through non-coal thermal means by 2022, which is more than twice the current capacity. Water requirement under NEP estimates will be 1.52 BCM for non-coal thermal electricity production.

Thus, NEP and government's efforts to promote non-coal base electricity production, especially solar energy, will reduce stress on water sector also. This will allow for availability of additional water in our river systems.

Projections under Climate Change scenarios

Global warming led climate change is a major challenge affecting the water availability scenarios in the country. As an additional factor to rapidly increasing population, depletion of natural habitats and resources, climate change is projected to have direct impacts on livelihoods and raising concerns for food security, water supply, health and energy.

Changes in temperature pattern due to global warming have consequential impacts on precipitation patterns, both globally as well as regionally. As precipitation is the key regulator of surface water availability in any area, it gets severely affected due climate change. According to Intergovernmental Panel on Climate Change (IPCC) report in 2014, climate has shown warming of 0.89 [0.69 to 1.08] °C over the period 1901–2012 which is mainly attributed to anthropogenic activities.

While climate change is supposed to have an impact on water demand also, through its influence on production of crops, evapotranspiration from crops, human water demand, increasing pollution levels in water resources etc., no reliable records are available to understand alterations in water demand patterns under future climate change scenarios.

Hence, we focused future projections under climate change perspectives into variations in surface water availability and find the water stress scenarios under Business as Usual scenarios of water demand.

Changes in Rainfall patterns

Indian Meteorological Department (IMD) has reported that State averaged annual rainfall trends have increased over Andhra Pradesh, Bihar, Gujarat, Haryana, Jammu and Kashmir, Jharkhand, Lakshadweep, Manipur, Meghalaya, Mizoram, Orissa, Rajasthan, Tamil Nadu, Tripura and West Bengal during 1951–2010. However, annual rainfall has decreased over Andaman and Nicobar, Arunachal Pradesh, Assam, Chhattisgarh, Delhi, Goa, Himachal Pradesh, Karnataka, Kerala, Madhya Pradesh, Maharashtra, Nagaland, Punjab, Sikkim and Uttar Pradesh. The highest increase and decrease in annual rainfall were observed over Meghalaya (+14.68 mm/year) and Andaman and Nicobar (-7.77 mm/year) respectively. However, annual rainfall trends have been significantly increasing over West Bengal (+3.63 mm/year) and significantly decreasing over Andaman and Nicobar (-7.77 mm/year) and Uttar Pradesh (-4.42 mm/year).

1.1.1.7 Regional Changes in Rainfall pattern

An analysis of data from Indian Metrological Department to understand the regional variations in rainfall pattern indicates that maximum decrease in rainfall has taken place in northern region. Four out of five studied states in northern region show a decline in rainfall, with Haryana being only exception showing a slight increase in annual rainfall. However, it's the rainfall during the summer season in Haryana, which is increasing. Rainfall during post-monsoon season in Haryana also shows declining trend.

On the contrary, annual rainfall shows increasing trend in all the states of eastern region, with an annual increase of upto 3.6 mm in West Bengal, which shows an increase in almost all the seasons, while there is an increase in annual rainfall in Odisha, both monsoon and post monsoon rainfall is decreasing in the state.

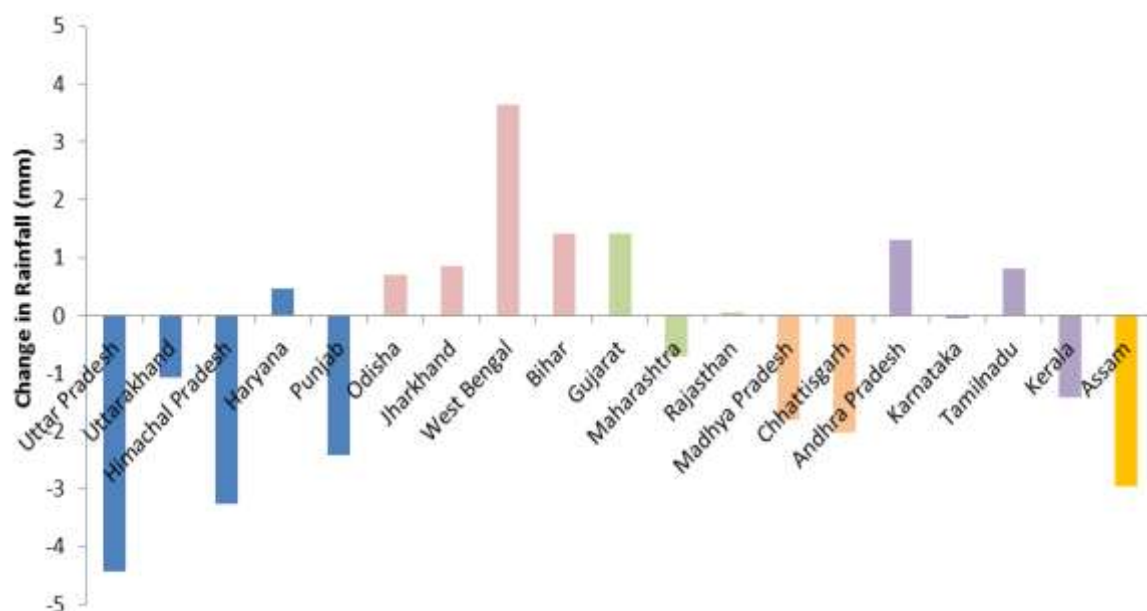

Figure 4.12 : Changes in rainfall pattern for states

Western and Southern region show a mixed trend with an increasing rainfall in some states and decreasing rainfall in some states. Rainfall in states like Gujarat and Andhra Pradesh has increased by more than 1 mm per annum, Tamil Nadu also shows slight increase which mainly during the post monsoon season. In Tamil Nadu, an equivalent decrease in rainfall during monsoon season, counterbalance the increase during post monsoon season, and on an annual scale there is only a slight increase.

Within the north-eastern region, major states like Assam and Arunachal Pradesh are showing a declining trend of rainfall as compared to smaller states like Meghalaya and Tripura, which are showing an increasing trend in rainfall.

Changes in Surface Water Availability Pattern

Changes in rainfall patterns have direct influence on surface water availability in a region. An increase or decrease in rainfall gets directly reflected in an increase or decrease in water availability. However, quantum of increase or decrease in rainfall may not follow the same quantum of increase or decrease in water availability in the region. Moreover, cumulative change over a period of time shows significant changes in quantity of surface water available in the region.

Corresponding to maximum decline in rainfall, northern region shows maximum decline in surface water availability. For the mid-century time period, water availability in Uttar Pradesh and Punjab shows a decline of 18% and 15% respectively, while increase in Haryana is limited to 3%. Overall the region shows a decline of about 13% in total surface water availability, by 2050.

On the contrary, eastern region shows an increase in water availability. Corresponding to increase in rainfall, all its states show an increase in water availability with maximum in West Bengal. Among the states of eastern region, Odisha shows minimum increase in surface water availability limited to 2% over 40 years upto 2050.

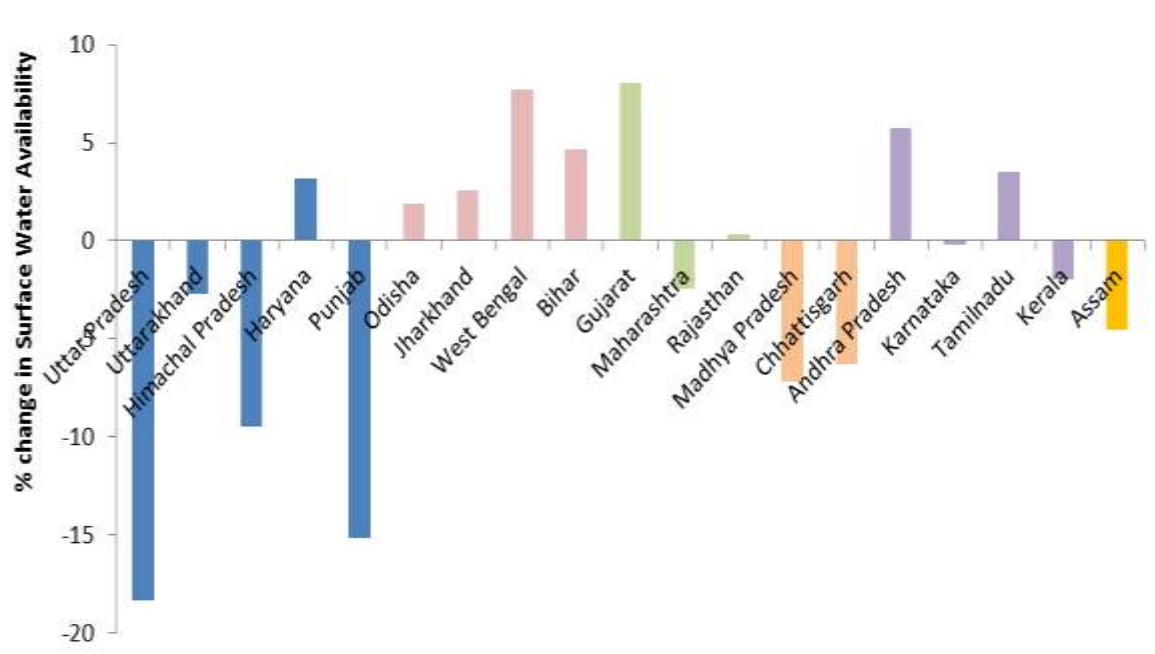

Figure 4.13 : Percentage change in Surface Water Availability under Climate Change Scenario

Among all the states of the country, Gujarat shows maximum increase in surface water availability, balancing the declining trend in Maharashtra and maintaining the water availability to its current levels, in western region. Overall, the country is likely to experience a deficit of about 2.3% in surface water availability, if the current trend of climate change impact continues until middle of this century.

Changes in Water Stress under Climate Change Scenario

To understand the impacts of climate change induced variations in water availability on the water stress scenarios, increased water requirement under business as usual scenarios was compared with the modified surface water availability. Additive effects of increase in demand and simultaneous decrease in water availability have profound impact on deteriorating the water stress scenarios, over time both at the national level as well as regionally.

Similar to BAU scenarios, maximum change in water stress situation is observed for Northern and western regions. However, northern region is likely to be under 'very high stress' condition in 2021 itself, and the intensity of stress increases by almost 5 percentage points, every decade. Similarly, current stress level of 'medium stress' in western region while intensify during the first two decades until 2031, but subsequently the region shifts to 'high stress' level. Water stress in north-eastern and eastern regions while intensifies throughout the projection period, it remains within the 'low stress' and 'medium stress' levels, respectively.

But the most remarkable response is noticed for eastern and southern regions, where the water stress reduces, though minimally, under the climate change scenarios. Water stress scenario improves in these two regions in response to increase in their water availability, making them biggest beneficiary of climate change impacts in India.

Nationally, impacts of climate change on water resources have very limited influence on water stress scenario, having an impact of only 0.1 percentage points as compared to water stress scenario under BAU scenarios. Country continues to remain under medium stress levels.

Table 4.5: Regional Water Stress under Climate Change Scenario

	NORTH	EAST	WEST	CENTRAL	SOUTH	NORTH EAST	NATIONAL
2011	69.7	28.9	41.2	23.2	29.2	4.8	37.2
	High	Medium	Medium	Low	Medium	Low	Medium
2021	75.4	30.5	45.7	27.0	31.3	5.8	40.5
	Very High	Medium	Medium	Medium	Medium	Low	Medium
2031	80.4	32.1	48.7	28.5	33.5	6.9	43.0
	Very High	Medium	Medium	Medium	Medium	Low	Medium
2041	84.9	34.2	51.3	30.3	35.4	8.7	45.4
	Very High	Medium	High	Medium	Medium	Low	Medium
2051	89.9	36.3	54.1	32.0	37.5	10.9	48.0
	Very High	Medium	High	Medium	Medium	Low	Medium

Efficient water use in Energy Demand & Supply Sectors

Water is a finite resource and as has been established in the previous chapters, all the sectors need water and they would depend on water as they grow in the future. However, water utilizable water resources are not growing at the same pace as the demand for water, and this is one of the limiting factors for expansion of energy sector. Therefore, it is imperative to efficiently use this limited yet the most important resource. Water is needed at different steps in various sectors. Some of the water conservation and efficient water use methods remain common for all the sectors, but there are some sector specific strategies that should be adopted by the sectors to become water efficient and ensure sustainable development in future of both water and energy sector. Both energy demand and supply sectors are discussed in this chapter and for some of the sectors existing best practices both at national and international level are also presented.

Energy demand sectors

The energy demand sectors, i.e. agriculture, domestic and industries require water for various purposes. But all the three sectors need to improve their water use efficiency. Agriculture is the most water intensive sector and it thus also provides a larger opportunity to improve water use efficiency. In domestic sector, most of the water is wasted during transmission and distribution phase with leakages as high as 30-40%. Also inefficient water use at household level is also one of the reasons for overall poor water efficiency in this sector. Industrial sector in India has generally 2.5-3 times more specific water consumption compared to existing international plants.

Since water is a stressed resource, thus it is important to efficiently use water and minimizes its wastage. This section discusses various strategies to improve water use efficiency in each of the demand sectors with some best practices from various parts of the world.

Efficient water use in agriculture sector

Agriculture is the most water intensive sector in India. More than 85% of water is demanded by the agriculture sector. But often it has been reported that the water use efficiency in the agriculture sector is poor and water is not efficiently used in agriculture sector. As per, Bhalage, P., et al., 2015, in India, the average water use efficiency of Irrigation Projects is assessed to be only of the order of 30-35%

- Agricultural water demand could be managed by the following strategies:
- Micro-irrigation system (MIS) including drip and sprinkler irrigation
- Bottle irrigation and Pitcher (Olla) irrigation
- Wastewater reuse

1.1.1.8 Micro irrigation Systems

Micro irrigation methods are precision irrigation methods with very high irrigation water use efficiency (70%- 90%). It is a rational method of irrigation where in the required amount of water and nutrients are given to the root zone of the plant. It saves significant amount of

water and also leads to increase in crop production. At present flood irrigation is the most prevalent form, which has low efficiency. MIS enables regulated supply of water at a required quantity and at required interval using pipe network, emitters and nozzles. Two main micro irrigation systems are Drip and Sprinkler irrigation.

a) Sprinkler Irrigation: in sprinkler irrigation, water is delivered through a pressurized pipe network to sprinklers nozzles or jets which spray the water into the air which falls on the surface imitating rainfall. The basic components of sprinkler systems are a water source, a pump to pressurize the water, a pipe network to distribute the water throughout the field, sprinklers to spray the water over the ground, and valves to control the flow of water. The sprinklers when properly spaced give a relatively uniform application of water over the irrigated area. Sprinkler systems are usually designed to apply water at a lower rate than the soil infiltration rate so that the amount of water infiltrated at any point depends on the application rate and time of application but not the soil infiltration rate.

b) Drip Irrigation, also known as trickle irrigation or micro-irrigation is an irrigation method which minimizes the use of water and fertilizer by allowing water to drip slowly to the roots of plants, either onto the soil surface or directly onto the root zone, through a network of valves, pipes, tubing and emitters. Drip irrigation minimizes conventional losses such as deep percolation, evaporation and run-off or recycled water is used for irrigation. Small diameter plastic pipes fitted with emitters or drippers at selected spacing to deliver the required quantity of water are used. Drip irrigation may also use devices called micro-spray heads, which spray water in a small area, instead of dripping emitters. These are generally used on tree and vine crops with wider root zones. Subsurface drip irrigation (SDI) uses permanently or temporarily buried dripper line or drip tape located at or below the plant roots. Pump and valves may be manually or automatically Irrigation methods operated by a controller. Emitter discharge rates for drip and subsurface irrigation are generally less than 12 litres per hour.

Benefits of Micro-irrigation system

As per the assessment done by the department of Economic Analysis and Research, NABRAD (2005), drip irrigation methods helps to save water and improve water use efficiency. It has reported that the water saving due to drip irrigation method varies from 12 to 84 percent over the conventional irrigation method across different research stations located in India for vegetable crop, while for fruit crop the range varies from 45 to 81 percent. Besides it also offer co-benefits like energy saving and increase in crop production. Some of them are listed below:

- It increases the productivity and yields of crops due to better air: water ratio thus increasing farm incomes.
- It reduces weed problems and soil erosion as the water is applied directly to the root zone in very small quantities.
- It also reduces problems of water logging, salinity and groundwater pollution.
- It reduces the cost of cultivation mainly due to savings in labour costs and energy savings. There is a reduction in labour costs due to reduced costs of weeding. The system reduces electricity costs as well because the same output can be obtained by using a low HP motor run for a short period of time every day. According to some estimates, the system can save electricity of 278 kWhr/ha for wide spaced orchard crops and 100 kWhr/ha for closely grown crops.

- Better crop output quality. The continuous and uniform application of water across the field will improve the quality of produce.
- Balanced use of nutrients and better fertilizer use. The use of water soluble fertilizers (WSF) is recommended with drip irrigation systems.

1.1.1.9 Bottle irrigation and Pitcher (Olla) irrigation

It is one of the locally available innovative solutions to save water. Pitcher irrigation also known as Olla is done using large flower pots or plastic containers. It is traditional method of drip irrigation which is used for container gardening or ground applications. It allows plant to uptake almost 100% of water thus making evaporation and other losses to almost nil.

1.1.1.10 Wastewater reuse

It is one of the most talked about options these days. Wastewater is considered as a resource which can be reused and agriculture is one such sector which has high potential for using treated wastewater. Most of the European countries suitably treat wastewater to a high standard which is then discharged into rivers where it gets diluted with the main flow and then re-used downstream for various purposes. Countries in North Africa and Middle East are exploring the potential of treating and reusing wastewater. In Israel, around 67% of wastewater is reused and mostly for irrigation and environmental purposes (FAO, 2010a). Another study (Mejia, 2010) indicates that in Mexico, around 25% of municipal wastewater is reused for irrigation purpose and it irrigates around 3 Lakh hectares of land.

Case Studies

1.1.1.11 Jai Malhar Water user Association, Indore Minor Irrigation Project, Dist: Nasik

Indore Minor Irrigation project has a command area of 157 hectare. Before implementing innovative project, only 20 to 30 hectare area was getting the irrigation benefit as there were huge conveyance losses in the conventional open channel water distribution network. The WUA replaced rejected conventional system of open channels and adopted innovative network of PVC pipe system for distribution of water. The water received by individual is then stored in well and this collected water is used through drip irrigation method on field. This has led to saving of water and enhancement of farm productivity.

Source: Bhagale, P., Jadia, B.B., and Sangale, S.T., 2015. Case Study of Innovative Irrigation Management Techniques, Aquatic Procedia 4 (2015) 1197 – 1202

1.1.1.12 Drip irrigation in the U.S¹

From 2003 to 2008, the area under sub-surface drip irrigation increased from 163000 to 260000 ha which is an increase of around 59%. Because of the immense environmental benefits, as well as the following factors led to rapid growth of drip irrigation system in the U.S.;

¹ <http://smartirrigation.co.nz/wp-content/uploads/2014/03/INZ-Bk7-DripIrrigation-Online.pdf>

- Water scarcity caused by periodic droughts and reallocation of existing water supplies for urban and environmental uses, and
- Minimizing environmental impacts of agricultural drainage and run-off associated with flood and sprinkler irrigation.

One of the most precise water and nutrient control technology is the drip irrigation. Intensive agriculture systems like vegetable production get good results from drip irrigation. This technology has acclaimed widespread acceptance internationally as a technology that can increase water use efficiency to about 90–95%.

1.1.1.13 Primarflor Lettuce Farm, Spain

Primaflor farm has integral soil moisture meters within the growing crop to monitor soil moisture levels. These meters have sensors to monitor moisture levels to regulate irrigation water amount. Additionally they have installed drip irrigation system which further saves water and have also increased the farm productivity.

1.1.1.14 Wastewater Treatment and Reuse in Spain²

In Spain, The Segura basin (Murcia) is the only basin whose natural water resources cannot cover its water demands. There is high agricultural water demand in the country. To tackle this situation, Murcia the treated municipal wastewater reuse in agriculture. In 2008, 106 hm³ of wastewater were treated in 80 wastewater treatment plants to irrigated 1600 ha of land.

Efficient water use in domestic sector

Domestic sector needs water for various purposes including drinking, washing and cleaning purpose. One of the ways to enhance water use efficiency in this sector is by managing the water demand through use of water efficient fixtures. Water-efficient appliances and fixtures can help save a significant amount of water and energy and result in long term cost saving as well. This help to conserve clean tap water and bring down costs of distribution and treatment as there is lesser volume of water to be treated and lesser wastewater generated. Significant savings can also be seen for a domestic user as well through a reduced water bill and lesser energy use, for example those who utilize booster pumps require lesser running of water. Some of the commonly used water efficient fixtures are mentioned below.

- a) **Faucet aerators:** These faucet aerators add air to the water flow. This mixing of air with the flow of water results in a steadier stream. These aerators are usually simple, mesh screen made of metal or plastic with some housing that can be easily attached to the end of a faucet. As water flows through a faucet aerator it is divided into many small streams by the screens and allows the air to mix in between. This allows for the sense of high pressure with less actual water consumption. These low cost aerators can help cut down on water usage, lower utility bills, and preserve the environment. Some of these aerators have been known to save up to 55% of water than a standard flow.
- b) **Low-flow or sensed faucets:** An automatic faucet or tap (also known as hands-free faucet/touch less faucet/electronic faucet/sensor faucet/motion sensing faucet

² https://www.researchgate.net/publication/46488842_Use_of_treated_municipal_wastewater_in_irrigated_agriculture-Review_of_some_practices_in_Spain_and_Greece

/infrared faucet) is a faucet that is equipped with a proximity sensor and mechanism that opens its valve to allow water to flow in response to the presence of a hand or hands in close proximity. The faucet closes its valve again after a few seconds or when it no longer detects the presence of hands. Automatic faucets shut off automatically after hand washing resulting in reduced water waste or overflow.

- c) Low-flush toilets and waterless urinals: The Indian Standard Code of Basic Requirements for Water Supply, Drainage and Sanitation states that out of the 150 to 200 litres per head per day, 45 litres per head per day may be taken for flushing requirements. These low-flush toilets and waterless urinals can save a significant water savings. Water Free Urinal Pots which does not use water for flushing can efficiently save water.

However, the major inefficiencies in this sector lie in the phase of water transmission and distribution. The leakage percentages in some cities are as high as 40%. Leakages and unaccounted for water must be reduced to the maximum extent possible and for that it is essential to detect leakages and losses by undertaking water audits. These leaks and losses should be controlled; water connections should be metered by installing smart meters. Some of the recommended interventions for domestic sector include:

- Metering (both at source and end-user level)
- Leakage control
- Well-designed tariff structures
- Pressure reduction
- Water conservation
- Reuse of water

Efficient water use in industrial sector

Like domestic sector, it is also important for industries to get water audit for their plant to identify leakages and losses and then explore avenues for saving water. Industries can opt for sector specific technological improvements to improve water use efficiency within their plant premises. Besides these sector specific opportunities to reduce water use, there exist many opportunities for industrial sector to reduce water consumption, conserve water and enhance water use efficiency. Some of the interventions that industries could adopt include but not limited to

- Reducing water footprint of the industry across its entire value chain and to enhance water use efficiency: this can be done by adopting efficient technologies which will also help increase industrial water productivity and thus will make business more sustainable
- Recycle and reuse of wastewater: this opportunity has a huge scope and has already been implemented by many industrial units (textile industry in Tirupur).
- Institutionalize and undertake mandatory water audits & conservation measures: water audit is an important tool to identify water losses and leakages and help in identifying avenues for water conservation. Other interventions like rain water harvesting, artificial recharge of groundwater can help to augment the scarce water resource in the region.

- Setting up of standards and benchmark (e.g. minimal quantity of water used/unit of product) for water consumption and efficiency
- Renew business strategies with financial outlay for water saving (water policy of industries)

The industrial sector can ensure efficient use of water by adopting one or more of the listed interventions and this will help industries to combat to the challenges faced by the inter-sectoral water demand and climate change impact on water resources.

Other option for industrial sector is to adopt ex-situ approach in which watershed approach is adopted to conserve water beyond their premises. Through the CSR initiatives industries should undertake interventions on soil and water conservation which includes building check dams, constructing farm ponds, rainwater harvesting structures, artificial ground water recharge injection well, etc. This will help to augment the water resource of the region in which industry is located and also to adapt to the impacts of climate change. This will also help to build a better reputation with local community which are competing users for common resource in the watershed.

Case study: Vizag Steel Plant

Vizag steel plant has taken number of initiatives to conserve water in its plant. It is a first shore based steel plant of 3 MT liquid steel capacity. Water is mainly used for equipment cooling, absorption, steam generation, drinking & sanitary purpose, fire-fighting, plant process, gas-scrubbing. The table below presents various interventions undertaken by the plant, amount of water saved and pay-back period of the investment.

Table 5.1 Various water conservation measures (in last 4 years) in the plant

S. No.	Title of Water Saving project implemented	Year of Implementation	Annual Water Savings		Invest. made	Payback Period (Months)
			M ³	Rs. Lakhs		
1	Recycling of secondary spray cooling water in SMS 250 Cu. Mtr/Hr	June'04	2190000	131.4	296	27.03
2	Utilizing Cooling tower – 22 blow down in Mills	June'05	175200	10.5	2.5	2.8
3	Utilizing Cooling tower – 21 blow down in SMS	Aug'05	262800	15.7	2.5	1.9
4	Introduction of Ultra Filter plant	Jan'06	1752000	105	500	45
5	Installation of 2 nos of pumps in diversion channel to recover rain water	July'06	438000	165.7	470	34
6	Provision of side stream filters at TPP PH-04	Jan'07	438000	165.7	470	34

S. No.	Title of Water Saving project implemented	Year of Implementation	Annual Water Savings		Invest. made	Payback Period
7	Replacement of damaged pipe lines in various zones	Mar'07	876000	131.40	200	18
8	Settling tanks for recovery of metallurgical waste	Mar'07	876000	131.40	585	54
9	Diversion of exhaust cooling water in BHS 1 to PH-6	Dec'07	350400	52.56	2	1
10	Renovation of all cooling towers in coke oven area	Feb'08	438000	65.70	100	18

Energy Supply Sectors

Water is also an important input in the processes of energy production by various supply sources. For various energy supply sectors, water is needed at different levels. This section discusses possible interventions to reduce water consumption for the following supply sectors:

- Fossil-based power generation
- Nuclear power stations
- Renewable based bio-energy
- Oil & gas extraction

Efficient water use in Fossil based power generation

Thermal power plants are the most intensive water user in the industrial sector. This section would focus on enhancing water use efficiency in coal based thermal power plants. Some of the key strategies to reduce water footprint in the coal based power plants include the following:

Reducing Footprints of cooling water requirement

There are two widely implemented types of cooling for power production - once-through cooling and closed-loop cooling. Once-through cooling systems use the nearby water to help cool the condenser water. The water consumption at the power plant is minimal, if not zero, because the water does not directly contact the air. A closed-loop cooling system was designed to minimize the amount of water withdrawn from the river. In this system, the condenser water still exchanges heat with water in a heat exchanger, but the cooling water is recycled between a cooling tower and a heat exchanger. In the case of closed cycle wet cooling systems, use of cooling towers result in evaporation losses cooling water flowing around hot water. Dry cooling is typically more water efficient, both from a capital cost and an operational cost aspect, because dry cooling uses little or no water and needs less maintenance than cooling towers that require water. Dry cooling is the most attractive cooling system when considering water withdrawals and water consumption for power production.

Reducing Footprints in ash disposal

Ash handling is a major challenge for all the coal based thermal power plant across the country due to environmental concern and their intensive water requirement where demand of fresh water for ash handling governed by number of factors such as coal quality, ash production, type of ash disposal system, ash utilization and waste water management. In general, power plants consume about 40% of total fresh water in their ash handling system.

Wet ash disposal is another major user of water in thermal power plants. There are two kinds of ash generated in power plants; fly ash and bottom ash. There are basically three broad approaches to reduce water footprint of ash disposal. The first approach is to make sure that the ash production is minimized. This depends on the quality of coal used. Clean coal technologies are available to mitigate impacts of coal based energy generation. One can use better quality coal to reduce production of ash. Another approach is to reduce water used for ash disposal. Additionally, the burden on fresh water can be reduced by using treated wastewater and cooling water blowdown for ash handling. The third approach is to recover ash water. The recycled water from ash pond could be used for make-up water in cooling towers.

Case Study: Indira Gandhi Super Thermal Power Project, Jhajjar

This project features complete dry ash collection from ESP hoppers and disposal by High concentration Slurry Disposal system (HCSD) and dry ash system. This was the first large capacity station to adopt the HCSD system. This system is designed for Ash water ratio of 6:4 to conserve water as compared to 1:5 ash water ratios used in conventional ash slurry disposal system.

Apart from this, the plant also features NTPC's first Reverse osmosis (RO) Plant being installed to recycle the waste water of station. Ash water re-circulation system is installed to re-use the ash slurry disposal overflow water. The waste water management system in the plant is designed for zero effluent discharge.

Wastewater management

Thermal power plants are one of the most water intensive industries. As it consumes huge amount of water, it also discharges large volume of wastewater. There are two types of wastewater generated from the power plants; wastewater associated with the plant operations, and domestic wastewater.

Various operational processes in thermal power plant that generate waste water include cooling tower blow-down, ash handling wastewater, wet FGD system discharges, material storage runoff; metal cleaning wastewater; and low-volume wastewater, such as air heater and precipitator wash water, boiler blow-down, boiler chemical cleaning waste, floor and yard drains and sumps, laboratory wastes, and backwash from ion exchange boiler water purification units, resin regenerator wastewater.

Case study: Zero Liquid Discharge (ZLD)

Zero liquid discharge refers to the system where all wastewater generated is either retained on the site or reduces to solids for disposal off site. It has been implemented in Calcutta Electric Supply Corporation (CESC) - BUDGE Budge power plant, West Bengal,

JSWELTorangallu power plant, Karnataka. The ZLD system ensures that water discharged from various processes is recycled back into the plant.

Efficient water use in Nuclear power stations

For nuclear power plants, water is required at various steps across its value chain. Water requirement starts from construction, commissioning, operation, shut-down and is needed until decommissioning phase. This section will mainly focus on effectively using water during operation phase. Commonly, nuclear power plants use water for cooling in 2 following ways:

- For conveying heat from reactor to steam turbines
- For removing surplus heat from steam circuit

The two commonly uses strategies include recycling of cooling tower blow-down and applying variable speed for drive pumps and tower fans³.

The variable speed drive pumps can be used for various cooling systems to reduce water withdrawal for both once through and closed loop circuits. It leads to lesser cooling water requirement during part load operations and shut-down operations.

Increasing cycle of concentration of cooling tower also helps to reduce water requirement of the nuclear power plants. Besides other benefits like, minimizing waste generation, decreasing chemical treatment requirements, and lowering overall operating costs.

Treatment technologies like Micro filtration (MF) and reverse osmosis (RO) on cooling water blow-down can help to recycle 85–90% of blow-down as make up water.

Hybrid cooling towers are also an innovative technology for saving water. With both wet and dry components in a common system and can be used separately or simultaneously for either water conservation or plume abatement purpose.

Case study: Palo Verde Nuclear Power Plant

This plant in USA is an exemplary case of use of grey water in NPP which is an innovative way of reducing fresh water consumption. Palo Verde obtains all its cooling and plant water from the wastewater treatment facility. Reverse Osmosis is used for obtaining drinking water. Rest of the water is treated to use as cooling water.

Efficient water use in renewable based bio-energy

For bio-energy production, bio-crops are grown and for enhancing the water use efficiency in production of bio-crops, efficient irrigation management practices should be adopted. (Efficient irrigation practices are provided in the agriculture section).

³ http://wstagcc.org/en/wp-content/uploads/sites/2/2015/02/IBRAHIM-KHAMIS_IAEA_WAMP.pdf

Efficient water use in oil & gas extraction

Water is an important input in the process of oil and gas extraction. Some of the best practices in the form of case studies in oil and gas sector are presented below.

Queensland Gas Corporation (QGC) PROJECT

In 2014, the QGC Project started producing LNG from natural gas sources from coal seams, which can produce up to 8.5 million tonnes of LNG a year. It supplies natural gas to both the domestic market and LNG to international customers.⁴

The gas field spans 4,500 square kilometers with plans for drilling 6,000 wells by 2030. Veolia was contracted to treat the production water of each new well brought on stream. At the same time as the methane, production water is also pumped up from the wells. This water has high salt content and must be treated before it can be reused in industry or agriculture. Cumulatively, almost 200,000 cubic meters was treated per day and a very high-quality water is guaranteed on a long-term basis.⁵

Coincidentally, the Northern Water Treatment Plant (NWTP) in Queensland has been named 'Industrial Water Project of the Year' at the 2016 Global Water Awards which is the water industry's most impressive technological and environmental achievements in a range of categories. This plant which costs 540 million Australian dollar features ultra-filtration, ion exchange technology, three-stage reverse osmosis and brine concentration, resulting in only three per cent waste brine water. The extensive use of digital engineering (DE), Design for Manufacture and Assembly (DfMA) techniques and modular construction aided to save costs and time. This plant is the largest of three treatment plants constructed for the Queensland Gas Corporation (QGC) by a General Electric (GE) and Laing O'Rourke joint venture for reusing water produced as a by-product of coal seam gas extraction. This project which was completed in 2015 is currently known to be one of the most efficient water treatment facilities. The plant treats 100,000m³ of production water each day and around 97,000m³ of river-quality water for agricultural use is produced.⁶

Petroleum Development Oman: Natural water filtration

The Nimr oilfields in Oman produce thousands of barrels of oil every day. However, only 10% of the liquid brought up is oil while most of it is water.⁷ Approximately 250,000 m³/d of water is required to be managed for oil production. Nimr water treatment plant (NWTP) project which is designed to treat 45,000 m³/d (However, since 2011, about 100,000 m³/d of produced water is being treated) is located in the south of Muscat in Oman. This project was co-executed by Petroleum Development Oman (PDO) and Bauer Environment. The produced water from the oilfield is brackish; with total dissolved solids (TDS) ranging between 7,000 mg/l and 8,000 mg/l and the oil content in the water is higher than 400 mg/l in average.⁸

⁴ Shell Sustainability report 2016

⁵ <http://www.veolia.com/en/our-customers/achievements/industries/oil-gas/australia-qgc>

⁶ <http://www.infoworks.laingorourke.com/sustainability/2016/world-class-accolade-for-water-treatment-plant.aspx>

⁷ <https://www.youtube.com/watch?v=am-xtIF5Zds>

⁸ Dr. Roman Breuer, Nimr Water Treatment Project Oman, BAUER Umwelt GmbH, Schrobenshausen, Germany August 2011

The layout of the plant includes a pipeline, which brings the produced water to the NWTTP system. There is an oil and water separator which helps to address the issues of loss of revenue from oil left in produced water. The settling tank and centrifuge systems help remove and reclaim any residual traces of oil. Through gravity feed the produced water is then distributed into a wetland facility where it is channeled through four wetland terraces which have an area of 2.3 million m². The water flows into the beds to be cleaned by microorganisms that live among the roots of the reeds as well as by algae.⁹

As the whole facility is made on a slope, the produced water does not require energy for pumping etc. to flow through the reed bed, making the plant both highly energy-efficient and extremely reliable.

Dawson Creek Reclaimed Water Project

Dawson Creek, in British Columbia, Canada is an area that is prone to water shortages. With the oil and gas discovery in the area, prospects to extract these resources were hit with the issue of water availability. This led to the development of an innovative partnership in responsible water management between the City of Dawson Creek and Shell Canada.¹⁰

Through this partnership an effluent treatment facility at Dawson Creek was built that eliminates Shells' need for Peace River water at its nearby Groundbirch natural gas venture. Shell's Groundbirch facility, which is located approximately 48 kilometers from Dawson Creek, has five natural gas processing plants and over 300 wells.

Shell will not be drawing water from its 5,000-cubic-metre-a-day license on the Peace River. As per the Dawson Creek mayor Mike Bernier the new plant will conserve up to 4,000 cubic metres of water a day at Shell's hydraulic fracturing operations. Russ Ford, executive vice-president in charge of Shell's onshore oil and gas business in the Americas said that not only do they have water that they needed for their operations but there is an excess that is now available for the city.

As on average Shell uses less than the 4,000 m³/day that the city's system produces, the excess water will be used by the city for watering parks and sports fields, and will be sold to other gas companies, bringing in additional revenue to the city.¹¹

Urban Systems, the technology partner in the project selected a combination of biological treatment, wastewater filtration, and disinfection to provide treated municipal effluent for industrial operations. The Submerged Attached Growth Reactor (SAGR) which uses a horizontal trickling filter was combined with other technologies to ensure that reclaimed water meets the regulatory requirements for both municipal and industrial water uses. The system was designed to produce 4000 m³/day, out of which Shell is entitled to receive 3,400 m³/day for 10 years along with an option to renew for another 10 years. The unused 600 m³/day of reclaimed water, is being sold to other local industries.¹²

⁹ <http://www.shell.com/sustainability/environment/water/a-natural-filter-for-water-the-nimr-reed-beds.html#>

¹⁰ <http://www.dawsoncreek.ca/departments/infrastructure/water-environmental/water-reclamation-waste-water/>

¹¹ <http://www.vancouversun.com/technology/shell+uses+recycled+water+dawson+creek+fracking/7208998/story.html>

¹² Dawson Creek's reclaimed water facility is the first of its kind, Water Supply, Environmental Science & Engineering Magazine, May 2013, pp 18

Sustainable ZLD water management solution to Qatar Petroleum and Shell at Pearl GTL complex

Qatar has a dry, subtropical desert climate, with hot summers as well as low annual rainfall. This makes it imperative that water conservation is done for a business that utilizes a large amount of water to survive. Pearl GTL is the world's largest plant to turn natural gas into cleaner-burning fuels and lubricants.

Consequently, the plant produces a significantly large amount of water as compared to gas-to-liquids products. This is due to the occurrence of a chemical reaction when synthesis gas is passed over catalysts in a gas-to-liquids (GTL) plant resulting in the production of water as well as the building blocks for GTL products. This water makes it feasible to run the plant without using Qatar's scarce natural fresh water resources or seawater. Pearl GTL's industrial water processing plant is the largest recovery, treatment and reuse of industrial process water in the world.¹³

A consortium was formed from a 50/50 joint venture between Veolia and Saipem and a local construction company, Al Jaber for the design-build of the Pearl GTL complex effluent treatment plant. Qatar Petroleum and Shell opted for a sustainable zero liquid discharge management solution. The water produced in the transition from gas to liquid is led to an effluent treatment plant with a capacity of 45,000m³/day, where it is treated and reused in the production process. The plant was designed and completed by Veolia and their patented technologies were used. Wastewater was treated by ultrafiltration and reverse osmosis, for complete reuse within the factory process. In order to ensure ZLD the reverse osmosis brine treatment was done through evaporation and crystallization where only salt crystals are produced.¹⁴

It is important for all the energy demand and supply sectors to use water efficiently and minimize the wastage of water. Some recommendations which are specific to the sector have been discussed in previous sections. Besides reducing water wastage, all the sectors can adopt various water conservation measures like rainwater harvesting, groundwater recharge, waste-water recycle and reuse, etc. This would reduce the burden on fresh water resources and shift the sector towards water neutrality. With a country like India, where water is a stressed resource, every drop of conserved or saved water is important. Some of the good case studies for efficient water use exist within the country but needed to be widespread. Also these case studies provide policy makers a platform for informed decision making.

¹³ <http://www.shell.com/about-us/major-projects/pearl-gtl/producing-water-in-the-desert.html>

¹⁴ <http://www.veoliawatertechnologies.com/en/industrial-water-treatment-case-studies/oil-gas/shell-qatar>

Recommendation on change in policy, regulatory framework or institutional arrangement in India

Under National Action Plan for Climate Change of Government of India, one of the missions is the National Water Mission. One of the objectives of the National Water Mission is to increase water use efficiency by 20% in all the sectors but there is a strong need to give impetus to this mission and make some changes in other existing policies and regulatory framework. Some of the key recommendations for sustainable and efficient use of water resources are suggested below. These recommendations could be incorporated by amending some existing policies and institutional arrangement.

Hydrological unit

For water resources management, it is imperative to understand the hydrological unit of the water body. It could be as basin level, sub-basin level or watershed level. Management at administrative unit cannot help to solve the issue as water flow and hydrological cycle is based on the concept of hydrological units. For bringing any reform in the water sector it is necessary to understand the local hydrology and adopt an integrated approach for management of the resource and to reduce inter-sectoral competition and to enhance water use efficiency in various sectors.

Moreover, water should be managed more at decentralized level and hence local hydrological units should be considered for management of water resources. Thus the national and state policies should focus on management of water resources more at hydrological unit and any plan for development that has implication on water demand should be based on comprehensive assessment of water availability at hydrological unit level. Various states should identify hydrological units in their states, like watersheds and after detailed assessment of each of the watershed, demand sectors should be planned according to the water availability and priority of demand sectors. Since water availability is highly variable spatially, so water intensive developments could be done more in water rich areas than in water stressed areas.

Establishing Institutional synergies

Water is dealt by multiple institutes, which mostly lead to mis-management of the resource. There should be strong alignment and synergies between various departments dealing with water resources. State Water Resources Department and Irrigation and Command Area Development department, Water Board (Urban Local Body), etc. should chart out programs and plan together for ensuring improved water use efficiency. State should implement state water policies in tandem with the National Water Policy with a special focus on enhancing water use efficiency.

6.1.1 Need for Bureau of Water Use Efficiency

Though National Water Mission under Ministry of Water Resources, River Development and Ganga Rejuvenation has one of the objectives to enhance water use efficiency by 20% but there is a need for central monitoring agency which would be similar to Bureau of Energy Efficiency and should train and certify water auditors to carry out performance of water use efficiency for various sectors and prepare reports and disseminate findings. Also

the bureau should take up marking and labelling of water efficient products and technologies and make this information available in the public domain so that consumers are well informed before taking decisions.

6.1.2 Stakeholder participation

For efficient management of resource, it is equally important to ensure participation from users also. Besides policy makers, there are many other key stakeholders who should be part of planning and management. Formation of Water User Associations in some states has shown an exemplary way of managing agricultural water and the National Water Policy acknowledges the role of WUAs and policy mentions about giving statutory power to them to collect revenue, and other powers. Similarly, it is important to include stakeholders from all the sectors in a group that plans and manage the resource at local level. These stakeholders should be imparted necessary training and capacity building so that they make advancement in their sectors. In urban residential sectors, RWAs should be essentially part of committee for planning and management and they should be trained to outreach to their members on the issues of water conservation and reducing water wastage at household level. Similarly, industrial associations should be trained to undertake various water saving interventions at individual plant levels.

6.1.3 Water as economic good

Water is not rightly priced and it is one of the major reasons for wastage of water in various sectors. After meeting the basic needs of drinking water and sanitation, water has to be treated as economic good and it should be priced accordingly. It should be made mandatory for all water utilities to recover their cost and emphasis should be on developing right tariff structure which could be slab-based.

Tariff for industrial and commercial users should be prescribed such that it motivates users to invest in recycling reuse and other options to reduce fresh water consumption.

6.1.4 Benchmarking and water audits

To minimize water wastage and to efficiently use it is important to set a benchmark of water use for various sectors. These benchmarks should be made mandatory for all sectors to abide by. Firstly it is important to set benchmarks for various sectors as there are no standards for water consumption in majority energy demand and supply sectors. To achieve these benchmarks it is important to undertake water audit exercise to detect leakages and also establish baseline of water use in a particular area. This would also help to explore avenues for water conservation and enhancing water use efficiency.

6.1.5 Management Information System

Management and sharing of data in water sector is poor and this is another limitation in ensuring efficient and sustainable management of the resource. Thus a central data base and information system which is robust and regularly updated should be made and it should be available in public domain.

6.1.6 Financial incentives and dis-incentives

For the sectors taking up water conservation measures including installation of water efficient fixtures/devices/technologies, government should provide some financial incentives to encourage them and attract more participants. On the other hand defaulters should be heavily fined. This has been recommended in the National Water Policy 2012, that incentivization of recycle and reuse but it has not been institutionalized.

Specific Policy Recommendations for Thermal Power Plants

Since Thermal power plants are the most water intensive sector, some of the recommendations specific to thermal power plants are:

6.2.1 Developing Water Source Management plan

As per new TOR for EIA study, upcoming power plants have to submit source of water and its sustainability in lean season. Concern about water source is a promising move. However, for the existing power plants, no such regulation exists. For existing power plants, there is no environmental regulation concerning withdrawals and sustainability of water source by undertaking interventions at watershed level to improve water situation in the surroundings. Thus this should be considered and even the existing power plants should be asked to prepare and submit the water source management plan including implemented or proposed water conservation plans for ensuring sustainability of water resources.

6.2.2 Reducing overall water footprints of power plants

Considering the future water demand from both upcoming thermal power plants and sectors like agriculture and domestic, reducing specific water consumption will have only a short term effect in improving overall water balance of the country.

Adopting a more comprehensive approach, thermal power plants must be asked to reduce the water footprints of their operations. The concept of water neutrality must be made mandatory for power plants, which require them to return back an equivalent amount of water to the hydrological system as consumed by them.

6.2.3 Mandating zero liquid discharge (ZLD)

ZLD has been made mandatory for upcoming power plants but this should be prescribed for both the existing as well as new power plants. ZLD is treatment process which treats all the wastewater produced by the entity and recycles and reused in the premises, leaving zero discharge at the end.

Annexure

Water-Energy Nexus Footprinting of Thermal Electricity Production

Thermal power plants use a heavy amount of water for electricity generation in various processes of the system, especially in the cooling towers, ash handling, DM water generation, drinking water supply and in other processes. In this context, as part of its ongoing research programme under current as well as some other previous projects, the team studied several thermal power plants to understand the Specific water consumption of specific power generating processes (PGPs) and to explore the potential for reduction of water consumption, and optimization of water use patterns. Field visits consisted of questionnaire based survey as well as monitoring/measurements of flows of the water supply network, as per the requirement. Understanding developed from these visits has been used in finalizing the intensity of water in thermal power plant sector.

Objective of the Study

1. To study the water consumption of different power generating processes (Cooling water, Ash handling, DM water, Fire water, Service water, etc.), and establish specific water consumption of the various types of power plants

List of the Visited Power Plants

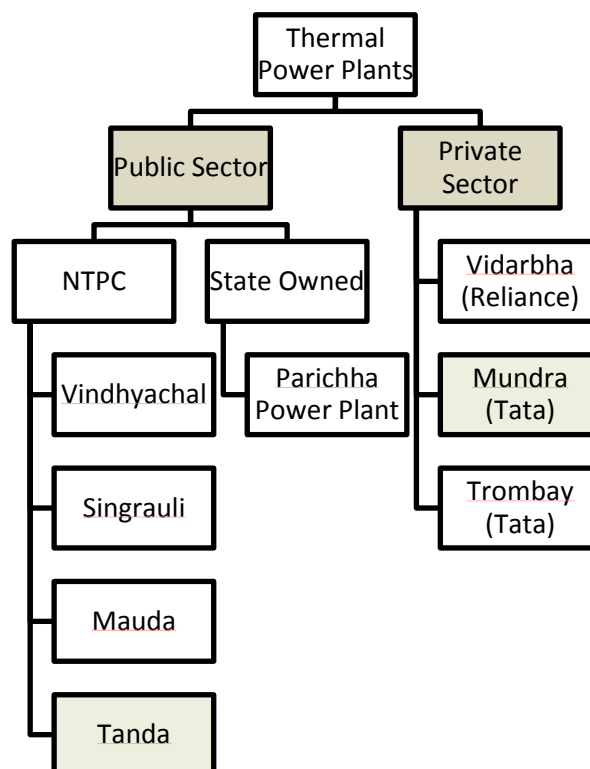

Singarauli Super Thermal Power Station

NTPC Shaktinagar is a township of NTPC Limited, for Singrauli Thermal power plant. It is situated in the state of Uttar Pradesh in Sonbhadra district. Shaktinagar Township is situated at a distance of 1 Km from Shaktinagar railway station, 25 Km from Singrauli station and 50 Km from Renukoot station. Singrauli is emerging as India's Energy capital.

Install Capacity

Stage-I (five units of 200 MW)	1000 MW
Stage-II (Two units of 500 MW)	1000 MW

Fuel Source

The coal linkage for this station is from the Nigahi Coal Mines of NCL. From there, the coal is transported by Railway transportation system (22 Kms length with double track) owned and operated by NTPC.

Water Balance Study

- 1. Water Source** – The plant draws required water through canal system from Rihand dam which is adjacent to power plant boundary. Water from the canal is collected in a raw water sump which constructed in the raw water pump building premises and supplied further for various uses in each stage.
- 2. Cooling Water** – Since it is once through cooling type plant, which require a heavy amount of water is about 59000 m³/h for 500 MW unit and this uses only once and drain back to its source.
- 3. Ash Handling** – Significant amount of water is used in power plant for handling the ash generated from the combustion of coal. Water is used to carry the ash from plant to the Ash dyke in the form of slurry.
- 4. Drinking Water** - Apart from power plant, some part of water is filtered and supplied as drinking water within the plant as well as the residential township
- 5. DM Water** - In this plant, Water is treated through ion-exchange system at the DM plants and further pumped into DM water storage tank for use in power generating units. During the DM water generation process a significant amount of waste water being generated which has high level of impurities that may further used in ash handling system.
- 6. Specific water Consumption** - Specific water consumption is a key indicator for assessing the performance of thermal power stations and it generally varies from 1.7 to 8.0m³/MW. This mainly depends on the size, age and the type of the plant (either coal based or gas based), type of water circulation (i.e. once through system or cooling tower based), dry ash handling system or wet ash handling system, provision for ash water recycling, etc.

As Singarauli Super Thermal Power Station is a once through cooling type plant it's require heavy amount of water and plant specific water consumption is nearly 180-200 m³/h.

Vindhyachal Thermal Power Station

National Thermal Power Corporation's (NTPCs) Vindhyachal Super Thermal Power Station (VSTPS) is situated in Singrauli district of Madhya Pradesh with the total approved capacity of 4760 MW and install capacity is 3760 MW. It is the largest coal based thermal power station in the country. The power plant has been running on a plant load factor of 85 - 92 per cent. Power generated from this plant provides to electricity requirements of Madhya Pradesh, Chhattisgarh, Maharashtra, Gujarat, Goa, Daman and Diu and Dadar Nagar Haveli.

Total Approved Capacity

Unit Size	Approved Capacity	Install Capacity
Stage I (6*210MW)	1260 MW	1260 MW
Stage II (2*500MW)	1000 MW	1000 MW
Stage III (2*500MW)	1000 MW	1000 MW
Stage IV (2*500 MW)	1000 MW	1* 500 MW (Running) 1*500 MW(Under Construction)
Stage V (1*500MW)	500 MW	Under Construction

Fuel Source

The coal linkage for this station is from the Nigahi Coal Mines of NCL

Water Balance Study

Water Source - Water for NTPC Vindhyachal is drained from NTPC Singrauli station discharge channel and stored in reservoir within the plant premises. The total water intake by the plant from the source is about 15805m³/h and stored water used further for various use.

Water Distribution

Major amount of water at NTPC Vindhyachal is used for ash handling as well as for cooling purposes in the different cooling tower of each stage in a closed cycle.

Water for Cooling Towers

This is the largest water consuming process in the power plant where the fresh water kept in close loop circulating system to condense the boiler steam. Cooling Towers are attached to each of the units of every stage to cool down the water received from the condensers. The circulating cooling water after picking up the heat in the condenser is taken to the cooling towers for cooling and further re-circulated in closed loop system. Water losses incurred in this process is made up as makeup water from the raw water source.

Vindhyachal Power station requires around 8130 m³/hr fresh water for makeup their circulating water in cooling towers.

Water for Ash Handling

A significant amount of water is used for ash handling in the power generation process. Water is used as medium to carry the ash slurry to the ash dyke of each stage. Vindhyachal thermal power plant use a plenty amount of water to settle their generated ash into ash dyke in the form of lean slurry.

The total amount of water requirement in this process is 4570 m³/h which is around 30% of total requirement of the water in the plant.

Water for DM Water Generation

In the plant, Demineralized water is very important in the plant for steam generation because raw water coming from different sources contains dissolve salts and of un-dissolve suspends. It is necessary to remove harmful salts and impurities before feeding it to the boiler because,

- The harmful dissolved salts may react with various parts of boiler through which it flows, thereby corrode the surfaces.
- Corrosion damage may occur to turbine blades.

In this plant, Water is treated through ion-exchange system at the DM plants and further pumped into DM water storage tank for use in power generating units. During the DM water generation process a significant amount of waste water being generated which has high level of impurities that may further used in ash handling system.

The total water requirement of the plant for DM water generation is about 174m³/h.

Drinking Water Supply

Apart from power plant, some part of water is filtered and supplied as drinking water within the plant as well as the residential township.

Around 902m³/h water is used for drinking purposes with the plant and their township.

Water for Firefighting

Apart from all the water use processes, water is also pumped for firefighting purposes in case of emergency. It was however observed that water from the fire hydrants of both stages is used for ash handling system, coal handling plant for washing, dust separation and other purposes.

Around 1100 m³/h water is kept in fire hydrants for the emergency.

Other Water Uses

Power plant uses around 1000 m³/h for different purposes such as gardening, sanitation, floor washing etc.

Specific Water Consumption of the plant

Processes	Water Consumption (m ³ /h)
Cooling Tower	8130
Ash Handling	4570
DM Plant	174
Drinking Water	902
Firefighting	1068
Others Uses	961
Total	15805

Source: Bureau of Energy Efficiency

Based on the water balance study, the specific water consumption is around 4.8m³/MW/h.

Tanda Super Thermal Power Station

NTPC Tanda situated at the bank of saryu river in Ambedker Nagar district Uttar Pradesh near to Tanda township with installed capacity of 440MW [4x110 MW]. In coming days NTPC proposed two new units Stage - 2 [2x660MW] each at same location which comes in existence in 2018.

Fuel Source - North Karnpura Coal Fields

Water Balance Study of the Power Plant

- **Raw Water Intake Channel** - 1730 m³/h raw water intake from Saryu River through pipe line and store in reservoir for further uses.
- **Cooling Tower** – Total 748m³/h water is being consumed by cooling towers in Tanda thermal power plant.
- **Ash Handling** - Team visit ash dyke site which establish in three part Ash dyke A, B and contingency ash dyke. Bottom ash deposited in ash dyke through pipe line in the form of slurry where 850m³/h water is used. 100% fly ash sale by plant to users. At present, out of the 850 m³/h Ash slurry water requirement is being met by CW blow down (230), OWRP-1(69), OWRP-2(13), Ash dyke over flow (150), and raw water makeup (350) m³/h respectively.
- **DM Water Plant** - At present, 160 m³/h water being used by DM plant to produce DM water for steam generation and other purposes (washing and regeneration of the DM plant). Total 800 m³ DM water is generated in a day and average 17000 - 21000 m³ DM water are produce in a month. Production of DM water is depend upon the requirement and store in the storage tanks which located in the DM plant premises. Currently, 58.63m³/h DM water is used by plant which derived from storage tanks.
- **Drinking Water** – around 152m³/h water being supplied for drinking for plant as well as in the power station township.
- **Service Water** - In current scenario, Total 64m³/h effluent water drawn from ash slurry sump to use for different purposes (hand wash, toilet and other services) consider as service water.
- **Firefighting** – 79.7m³/h water is used for firefighting in the plant through Hydrant 1, 2 and spray system. 75.59 m³/h water flows from Hydrant 1 and team found hydrant 2 and spray system in standing mode.
- **Other water uses** - Power plant used around 212m³/h for different purposes such as gardening, sanitation, floor washing etc.

Specific Water Consumption – Based on the water balance study, the specific water consumption is around 5.05m³/MW/h.

Tanda Super Thermal Power Plant	
Process	Water Requirement (M ³ /h)
Total Capacity (MW)	440
Cooling Water	748
Ash Handling	314
DM Water	160
Drinking Water	152
Service water	64
Fire Fighting	79.7
Others	212.3
Total Water Intek	1730

Vidarbha Industries Power Plant, Butobori, Nagpur, Maharashtra

Vidarbha Industries Power Limited (VIPL) subsidiary of Reliance Power Limited has implemented India's most compact coal based power project at MIDC Area of Butibori, Nagpur. The EPC Contract for the Project was placed between VIPL and Reliance Infrastructure Limited.

Total Install Capacity – 2*300 MW

Fuel Source - Domestic Coal supply is from WCL coal mines near Chandrapur/wardha and imported coal from Indonesia.

Water Balance Study

- Raw Water Source** - Raw Water intake from Wadgaon Dam on Venna River approximately 18 km from site.
- Water Distribution**
 - Cooling Water** – The plant requires around 720m³/h for cooling purpose and it's about 87 % of total water consumption by the plant.
 - Ash Handling** – Plant requires very less amount of water in this process because they recover maximum ash water from ash dyke and also use the blowdown water for ash handling which reduce fresh water requirement for this. Only 55m³/h fresh water is required as ash handling makeup water.
 - DM Water** – A total water requirement in the plant for DM water generation is about 41m³/hr water.
 - Drinking Water and Service Water** – Total 24m³/h water being used for drinking and service water supply.

Vidarbha Industries power Station, Butibori, Nagpur, Maharashtra	
Process	Water Requirements (m ³ /h)
Install Capacity	600
Cooling Tower	720
Ash Handling	55
DM Water	41
Drinking	6
Service Water	18
Total Water Requirement	824
Specific Water Consumption	1.5

Specific Water Consumption of the plant – SWC of this plant is very low which around 1.5m³/h.

TATA Ultra-Mega Power Plant, Mundra, Gujarat

Tata Power Company Limited is installing a thermal power plant at Mundra in Kutch district of Gujarat with the total install capacity of 4000 MW. The power plant is located at a site near south of Tundawand village in Mundra taluka of Kutch district in Gujarat coastal area. This ultra-mega project will establish India's first 800-megawatt unit super-critical technology thermal power plant, which is likely to be the most energy-efficient, coal-based thermal power plant in the country.

Total Install Capacity- $5 \times 800 = 4000\text{MW}$

Fuel Source – Imported coal from Indonesia coal mines which owned by TATA

Use of Sea Water

The seawater is drawn to the plant through an open channel excavated to a depth of about 3 m below lowest tide water level. The width of channel required would be about 100 m to draw an estimated cooling water flow of about 594,200 m³/hr. However, the full capacity of raw water intake channel is 620,000m³/hr. The intake channel would be routed through Kotdi Creek. An on shore pump house located within the plant boundary will house the cooling water pumps.

Sea water desalination: The Desalination plant which used to desalinate the sea water to meet the plant cooling, service and potable water requirements. The power plant will use desalinated water to the tune of 630,000m³/hr for cooling purpose and 25,000m³/day to meet operations, service and drinking water needs during full load operation.

Water for Cooling Towers

For condenser cooling, a once through cooling system is adopted by plant which is economical as the site is located in coastal area close to sea. Seawater drawn from the sea is conveyed to the fore bay/sump in the plant area through a skimmer wall and open intake channel arrangement. Since it is once through cooling type plant, which require a heavy amount of water is around 111740m³/h per unit. Hot water from condenser is led back to the sea through a seal well discharge channel arrangement.

Fresh Water Requirement

Sea water pumped by separate set of pumps from CW sump is passed through a thermal desalination plant (MED). The desalination water (Fresh water) is led to a desalinated water storage tank from where water is distribute to various services. Fresh water is used for other services such as Demineralization (DM) plant (for SG make-up), coal handling / ash handling system, potable water for plant / colony, air conditioning system makeup and plant service water.

Ash Handling System – As power plant used imported coal from Indonesia which is very efficient and produce very low amount of ash is about 15%. To deposit plant generated ash in the ash dyke they use lean ash slurry system and total water requirement is about 3825 m³/h desalinated water.

DM Water Generation - Demineralised water required for steam generator make up and auxiliary cooling water system makeup is generated from desalinated water through ion exchange type DM plant and total water drawn by DM plant from thermal desalination unit is 142m³/h.

Drinking Water Supply – Around 230m³/h desalinated water is use for drinking within the plant as well as in the township area.

Service Water Supply – Nearly 500m³/h fresh water is used for other miscellaneous services in the plant is pumped from the desalinated water storage tank to service water overhead tank from where water is distributed to various services.

Firefighting Water Supply - Plant maintain 273m³/h water in plant fire hydrant for emergency.

Other Water Uses: approximately 16110m³/h used in power plant for various operation and services.

Specific Water Consumption

Process	TATA UMPP	
	Sea Water	Fresh Water
Capacity in MW	4000	
<i>Cooling Tower</i>	111740	
<i>Ash Handling</i>		3825
<i>DM Plant</i>		142
<i>Drinking Water</i>		230
<i>Service Water</i>		500
<i>Firefighting</i>		273
<i>Other Water Uses</i>		16110
<i>Total Water Use</i>		21080

As per the estimation, Plant Specific Water Consumption of fresh water is nearly 5.8m³/h.



Water Balance Study of the Gas based Power Plants

1. NCPS, Dadri Combined Cycle Gas Power Station

NTPC Dadri is the power project established to meet the power demand of National capital region and commonly known as NCPS (National Capital Power Station). It is situated at Gautambudhnagar district of Uttar Pradesh, which is about 24 km from Ghaziabad and nearly 45 km from New Delhi.

NCPS Dadri is a unique power plant of NTPC group which has both thermal plant of 1820MW and gas plant of about 830 MW respectively.

The installed capacity of NCPS is about 2650 MW, which utilises coal from Piparwar Mines, Jharkhand and gas from HBJ Pipe line and water from Upper Ganga canal.

Technology: Combined Cycle Gas power station

Install Capacity -

Turbine	Unit Size*No. of Units	Total Capacity (MW)
Gas Turbine	130.19*4	520.76
Steam Turbine	154.51*2	309.02
Total Install Capacity	6	830

Dadri Gas Power Plant Water Balance Study

Gas plant at NCPS Dadri runs in a combined cycle where Power generation is done using gas and steam turbines systems. Water is required in the combined cycle for the thermal system and its circulation water for the respective condensers and cooling towers.

Water for Gas Plant is supplied from the raw water treatment plant. Clarified and softened water is supplied as makeup water to the CW pump house at Gas Plant for circulation in closed cycle and DM water is supplied to the power generating units for steam generation.

Raw Water Intake

Power plant draws raw water from Upper Ganga Canal which treated in raw water treatment plant.

Circulating water for Cooling Towers

In Dadri Gas Power Station, Each power Unit consists of two Gas turbines and one Steam turbine. Water at Steam turbine of each Unit is used in Condensers where it condenses the steam after it has been used to move turbine for power generation. Hot water from condensers is conveyed to the respective Cooling Towers where its temperature is brought down and cooled water from cooling tower will used further for cooling the steam and some

amount of water from cooling tower will used for service water, blow down water and in some other purposes after treatment.

Cooling Water

As per the assessment, Water received at the CW pump house of Gas Plant is directly pumped to the circulation water in closed loop. The amount of clarified water supplied as makeup water to the Gas Plant was is about 918m³/hour.

DM Water

As per the assessment about 5m³/day of de-mineralised water is presently supplied to the power generating units of Gas Plant.

DM water is distributed to individual power generating Units of Gas Plant where it is used in respective boilers to generate steam, which in turn is used in turbines for power generation.

Drinking Water

Apart from power plant water requirement, some part of water is filtered and supplied as drinking water within the plant as well as the residential township. Around 29m³/h water is used for drinking purposes with the plant and their township.

Water requirement for other purposes

As per the estimation, power plant required high amount of water for different purposes is about 445m³/h out of which 19m³/h water is used for equipment cooling followed by 256m³/h water for firefighting, 48m³/h water is used as sprinkler water for gardening and 122m³/h water is used for other services such as service water, blowdown water etc.

Water Consuming Process	Water Use (m³/h)	Water Consumption in %
Cooling Water	777	62
DM Water	5	1
Drinking Water	29	2
Others	445	35
Total Water Intake	1256	100%

Specific Water Consumption of Dadri Gas Power Plant

As Gas power plant has a combined cycle comprising 310 MW steam turbine and 520 MW gas turbine, hence for calculation 310 MW capacities has been taken to represent the steam turbine cycle where water is used at gas plant.

Specific water consumption of the power plant is 4.27m³/MW/h as per the PLF is 90%.

Auraiya Combined Cycle Gas Power Plant

NTPC Auraiya is the power project established to meet the power demand of Uttar Pradesh, Jammu & Kashmir, Himachal Pradesh, Chandigarh, Rajasthan, Haryana, Punjab, Delhi & Uttarakhand state. It is situated at Auraiya district of Uttar Pradesh. It's a combined cycle power plant which has a total install capacity of 652 MW out of which 440 MW produced by Gas turbine and 212 MW produced by Steam turbine.

Install Capacity

Turbine	Unit Size*No. of Units	Total Capacity (MW)
Gas Turbine	110*4	440
Steam Turbine	106*2	212
Total Install Capacity	6	652

Plant fulfils their fuel requirement from HBJ pipeline – South basin gas field and its draws required water from Auraiya – Etawah Canal.

Water Balance Study of Power Plant

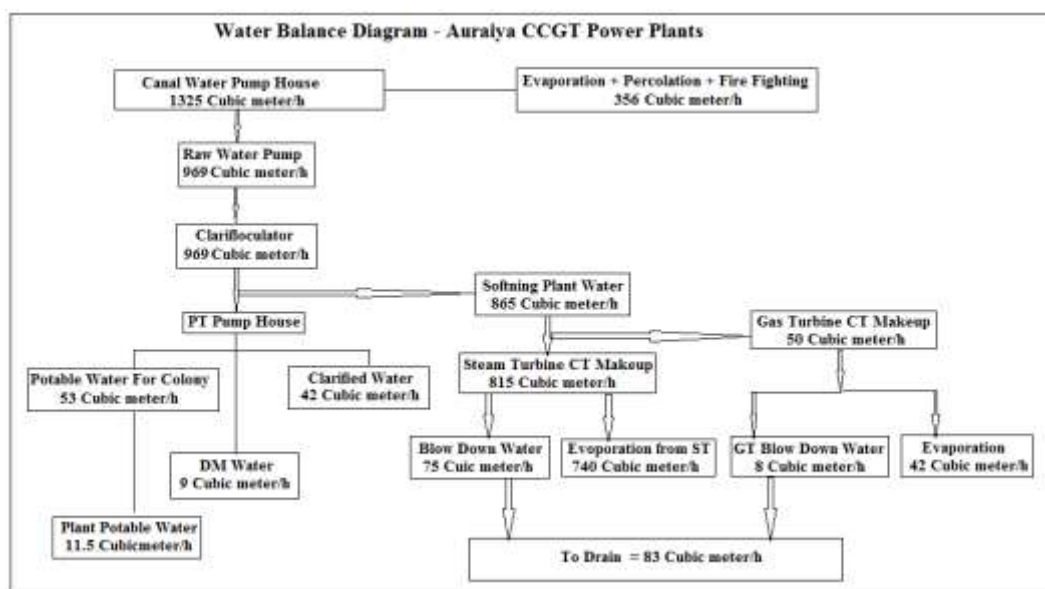

Raw Water Intake – Power plants draws required water from Auraiya-Etawah Canal through pumps where it takes about 1325m³/h water for plant operation out of which 969m³/h water pumped for primary treatment which will used in different processes.

Cooling Water – In Auraiya Gas Power Station, Each power Unit consists of two Gas turbines and one Steam turbine. Water at Steam turbine of each Unit is used in Condensers where it condenses the steam after it has been used to move turbine for power generation. Hot water from condensers is conveyed to the respective Cooling Towers where its temperature is brought down and cooled water from cooling tower will used further for cooling the steam.

Total 865m³/h clarified water is supplied for condenser cooling where 815m³/h water used by steam turbine out of which 740m³/h water losses through CT evaporation and 75m³/h water drain as a blow down water and Gas turbine takes 50m³/h water cooling.

Drinking Water

A total of about 64.5m³/h of filter water is supplied for drinking out of which 53m³/h water is supplied for township and 11.5m³/h water for plant.

DM Water - A total of about 9m³/h water is supplied for DM water plant.

Service Water – A total of about 42m³/h water is supplied as service water which will use in different purposes.

Water Consuming Process	Water Use (m ³ /h)	Water Consumption in %
Cooling Water	865	89.26
DM Water	9	0.92
Drinking Water	65	6.7
Others	42	4.33
Total Water Intake	969	100%

Specific Water Consumption of the Auraiya Gas Power Plant

As Gas power plant has a combined cycle comprising 212 MW steam turbine and 440 MW gas turbine, hence for calculation 212 MW capacities has been taken to represent the steam turbine cycle where water is used at gas plant.

As per the estimation, Specific water consumption of the power plant is 4.57m³/MWh.

Annexure

Realizing the full potential under Indus Water Treaty 1960

Indus water treaty signed between India and Pakistan prescribes below provisions for the sharing of water in Indus and its tributaries:

1. All the waters of the Eastern Rivers (Ravi, Beas and Satluj) shall be available for the unrestricted use of India.
2. India is under obligation to let flow all the waters of the Western Rivers (Indus, Jhelum and Chenab), and shall not permit any interference with these waters. However, India can utilize this water for the purpose of
 - a. Domestic Use
 - b. Non-consumptive use like navigation, transport etc.
 - c. Generation of hydro-electric power through new 'Run of River' plants and new plants on irrigation channels, subject to some specified conditions
3. For the purpose of use of water from western rivers for irrigation, the Indus Water Treaty 1960 specifies that:
 - a. India may continue to irrigate those areas which were being irrigated at the time of treaty
 - b. But, additional area can also be brought under irrigation from individual western rivers, subject to the ceiling as prescribed in treaty:
 - i. 70,000 Acres from the Indus
 - ii. 400,000 Acres from the Jhelum
 - iii. 225,000 Acres from the Chenab, of which not more than 100,000 Acres in Jammu

Thus, provisions of the treaty indicate that an additional land of atleast 570,000 acres can be brought under irrigation in Jammu and Kashmir. Land and irrigation statistics for the state show that total area irrigated in Jammu and Kashmir was 7.6 lakh acres and has increase to 12 lakh acres, from 1960-61 to 2012-13. Thus, over a period of 50 years since the treaty, total area irrigated has increased by 58% bringing additional land equivalent to 4.42 lakh acres under irrigation facilities. This also indicates that India has still not been able to utilize full potential of water utilization as available under the Indus Waters Treaty, 1960.

An assessment of additional area likely to be brought under irrigation due to realization of full potential available under treaty and the total crop area in the state of Jammu and Kashmir was conducted. Total crop area in Jammu and Kashmir is 1.16 million hectares. Currently, the irrigation intensity is 42% with total irrigated area limited to 0.49 mHa. An additional land equivalent to 0.128 mHa could be brought under irrigation facility as per the current limits prescribed under the Indus treaty and this could enhance the irrigation intensity to 53%, giving an improvement of 11 percentage points.

Incorporating the scenario of 100% rainfed area being covered under irrigation facility

Indian agriculture is largely rainfed. A major portion of cropped area is not covered under assured irrigation facilities and is dependent on the annual and seasonal variability in rainfall. This has direct implications on the annual food production in the country. At the national level, approximately 45% of net cropped area is covered under irrigation, indicating that about 75 mHa of remaining cropped area is required to be brought under irrigation, to achieve 100% irrigation intensity in the country.

The extension of irrigation coverage varies from one state to another, and so regionally it varies very significantly. Maximum irrigation intensity is observed in the states of Punjab, Haryana and Uttar Pradesh, while the least irrigation intensity can be observed in states like Jharkhand, Chhattisgarh and Maharashtra. Accordingly, additional efforts will be required for the states with low irrigation intensity, while expanding the irrigation coverage in the country.

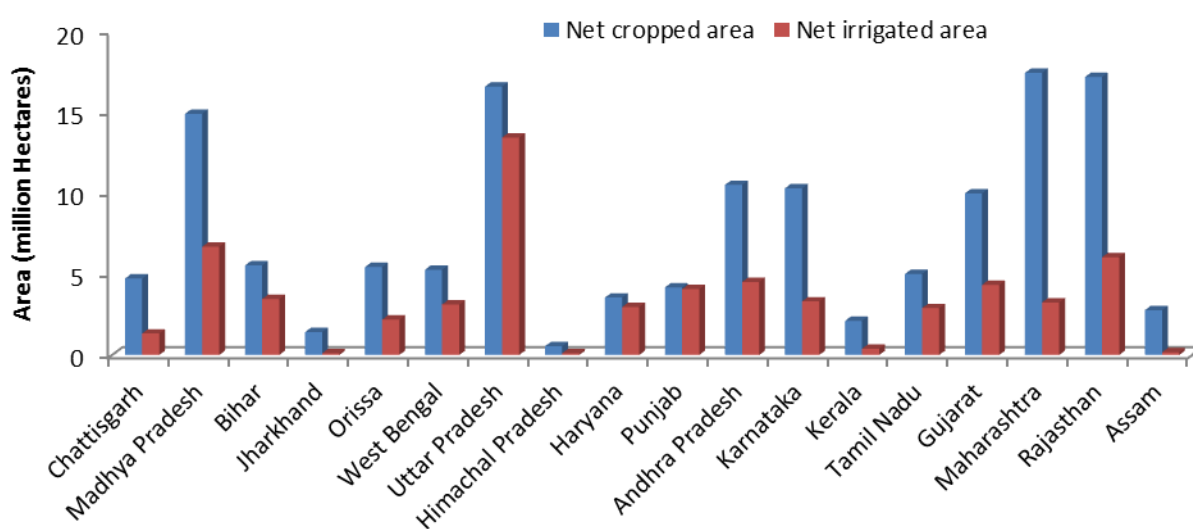

Water requirement for un-irrigated land

Maximum unirrigated area in the country is located in Maharashtra, Rajasthan and Madhya Pradesh. Together, this is equivalent to approximately 33 mHa constituting 44% of country's unirrigated agricultural land. We made further analysis of cropping and irrigation pattern in these three states. 47% of unirrigated land in Madhya Pradesh is under the cultivation of oilseeds, and about 35% of unirrigated land in Maharashtra and Rajasthan is under cultivation of coarse cereals. In Madhya Pradesh, for the irrigated oil seed cultivation, irrigation water requirement is limited to 1.4 BCM but to bring the unirrigated oil seed cultivation land under irrigation facilities, 15-20 BCM additional irrigation water will be required. For Maharashtra and Rajasthan, irrigation water requirement for unirrigated land of coarse cereals will not be very high considering their crop characteristics, but to extend irrigation facility to the entire crop area in these states, almost 2 times additional irrigation water will be required as compared to water being used for irrigation currently.

Disclaimer: The Energy and Resources Institute (TERI), New Delhi has received the grant under the Research Scheme of NITI Aayog 2015 to produce the document. However, NITI Aayog shall not be held responsible for findings or opinions expressed in the document prepared. This responsibility rests with The Energy and Resources Institute (TERI), New Delhi.



The Energy and Resources Institute

www.teriin.org